



**HAL**  
open science

# Novel polydentate phosphonic acids: Protonation and stability constants of complexes with Fe(III) and Cu(II) in aqueous medium

Nabila Aliouane, Salah Chafaa, Tahar Douadi, Jean-Jacques Hélesbeux,  
Mustayeen A Khan, Olivier Duval, Gilles Bouet

## ► To cite this version:

Nabila Aliouane, Salah Chafaa, Tahar Douadi, Jean-Jacques Hélesbeux, Mustayeen A Khan, et al.. Novel polydentate phosphonic acids: Protonation and stability constants of complexes with Fe(III) and Cu(II) in aqueous medium. *Heteroatom Chemistry*, 2010, 21 (2), pp.51-62. 10.1002/hc.20575 . hal-03250900

**HAL Id: hal-03250900**

**<https://univ-angers.hal.science/hal-03250900>**

Submitted on 5 Jun 2021

**HAL** is a multi-disciplinary open access archive for the deposit and dissemination of scientific research documents, whether they are published or not. The documents may come from teaching and research institutions in France or abroad, or from public or private research centers.

L'archive ouverte pluridisciplinaire **HAL**, est destinée au dépôt et à la diffusion de documents scientifiques de niveau recherche, publiés ou non, émanant des établissements d'enseignement et de recherche français ou étrangers, des laboratoires publics ou privés.

# Novel Polydentate Phosphonic Acids: Protonation and Stability Constants of Complexes with Fe(III) and Cu(II) in Aqueous Medium

Nabila Aliouane,<sup>1</sup> Salah Chafaa,<sup>1</sup> Tahar Douadi,<sup>1</sup> Jean-Jacques Hélesbeux,<sup>2</sup> Mustayeen A. Khan,<sup>2</sup> Olivier Duval,<sup>2</sup> and Gilles Bouet<sup>2</sup>

<sup>1</sup>Laboratoire d'Électrochimie des Matériaux Moléculaires et des Complexes, LEMMC; Faculté des Sciences de l'Ingénieur, Université Ferhat Abbas, DZ-19000 Sétif, Algeria

<sup>2</sup>Laboratoire SONAS, UPRES-EA 921, IFR 149 QUASAV, UFR Sciences Pharmaceutiques et Ingénierie de la Santé, 16 Boulevard Daviers, F-49045 Angers Cedex 01, France

Received 22 July 2009; revised 9 December 2009

**ABSTRACT:** The acido-basic and the complexation properties of di-, tri-, and tetra-phosphonic acids ( $H_6L1$ ,  $H_8L2$ , and  $H_{10}L3$ ) toward Fe(III) and Cu(II) were determined by potentiometric titration in aqueous media at  $25.0 \pm 0.1^\circ\text{C}$  with constant ionic strength (0.1 M,  $\text{NaClO}_4$ ). We have determined six, ten, and eight  $pK_a$  values for the di, tri, and tetra-phosphonic acids, respectively. In acidic conditions, e.g.,  $0 \leq \text{pH} \leq 5$ ; iron and copper presented a high affinity toward these ligands to give complex species. With the ligand  $H_{10}L3$ ,  $[\text{FeL}_3\text{H}_7]$ , and  $[\text{CuL}_3\text{H}_6]^{2-}$  were easily obtained at pH 1.8 and 2.7, respectively. We have determined ten stability constants for the  $H_{10}L3/\text{Fe}$  system and nine for the  $H_{10}L3/\text{Cu}$  one; six and four in the cases of  $H_8L2/\text{Fe}$  and  $H_8L2/\text{Cu}$  systems, respectively. Finally, five stability constants were calculated for the  $H_6L1/\text{Fe}$  system and four for the  $H_6L1/\text{Cu}$  one. We have not observed any insoluble species in these complexes in acidic medium as well as in alkaline solutions. © 2010 Wiley Periodicals, Inc. Heteroatom Chem 21:51–62, 2010; Published online in Wiley InterScience (www.interscience.wiley.com). DOI 10.1002/hc.20575

## INTRODUCTION

Polyphosphonic acids contain several groups  $\text{R-PO}(\text{OH})_2$ , and these compounds are well known for their complexing properties. Their high chemical stability and their high solubility in water allow their use in detergents [1–3], industrial water treatment [4,5], industrial cleaners, enhanced oil recovery operations, and in corrosion control [6–11]. They also find applications in medicinal chemistry as antiviral agents, acting as analogues of natural pyrophosphates [12,13]. They are also used to treat hypercalcemia [14].

Many iron chelators are already described and are commonly used to treat iron overload [15,16]. Although iron is involved in the control of the reactivity of oxygen species, it may also be a strong catalyst for oxidative reaction involving very reactive radical species [16,17]. Cu(II) derivatives are able to form very stable complexes with phosphonate ligands [18,19], and this cation was found to play an important role in the metabolism [20,21].

Some Fe(III) complexes with methylphosphonic acid and aminomethylphosphonic acid have been described [22]. These two ligands were found to form 1:1 Fe(III) to ligand ratio complexes. These complexes are  $[\text{FeO-PO}(\text{OH})\text{CH}_3]^{2+}$  (monodentate protonated) and  $[\text{FeO}_2\text{-POCH}_2\text{NH}_3]^{2+}$  (deprotonated

Correspondence to: Gilles Bouet; e-mail: gilles.bouet@univ-angers.fr.

Contract grant sponsor: University of Bejaia (Algeria).  
© 2010 Wiley Periodicals, Inc.

chelate), respectively. Chruscinski et al. determined the stability constants of Cu(II) complexes with phosphonic acid deriving from pyridine, imidazole, and pyrazole [23]. More recently, the study of intramolecular stacking interactions in ternary Cu(II) complexes formed with a heteroaromatic amine and 9-[2-(2-phosphonoethoxy)ethyl]adenine was published [24].

Chafaa et al. [25,26] have reported the acid-base properties of a series of (*o*-hydroxyphenyl) methylenephosphonic acids synthesized by Vogt et al. The stability constants of the complexes obtained from these ligands and bivalent transition metals cations [27,28] and a wide variety of lanthanide(III) cations and thorium(IV) were determined [29–31].

The stability of phosphonic acids metal complexes increases with increasing phosphonic groups in the ligand. In this way, we have previously described the synthesis, the purification, and the structural determinations of three new polyphosphonic acids: methylenebis[(2-hydroxy-5,1,3-phenylene)-bismethylene] tetraphosphonic acid ( $H_6L1$ ) [27] [6–8,10,11] phosphonic acid ( $H_8L2$ ), and  $H_{10}L3$ : {[2-hydroxy-5-(4-hydroxybenzyl)-1,3-phenylene]bis(methylene)}bis(phosphonic acid) whose structures are given in Table 1 [32]. In this paper, we report a detailed potentiometric study of the acido-basic and the complexation properties of these three new ligands with Fe(III) and Cu(II) cations in aqueous medium, at 25°C.

## EXPERIMENTAL

### Materials

The polyphosphonates acids were obtained according to the previously described procedures. Their identity and purity were confirmed using ES-MS spectrometry and NMR spectra [32].

### Potentiometric Measurements

The determination of  $pK_{ai}$  and  $\log \beta_{11i}$  values by potentiometric titration was carried out at  $25.0 \pm 0.1^\circ\text{C}$  with 0.1 M ionic strength ( $\text{NaClO}_4$ ). The acid solution was  $10^{-2}$  M, and 20 mL of this solution was then neutralized with 1 M NaOH solution up to pH 14. The complexation was studied in aqueous solutions with equal analytical concentrations ( $10^{-4}$  M) of the ligand and of the cation ( $\text{FeCl}_3 \cdot 6\text{H}_2\text{O}$  or  $\text{CuCl}_2 \cdot 2\text{H}_2\text{O}$ ). The titrating agent (NaOH,  $10^{-2}$  M) was stored in a glass container. All measurements were made in a thermostated 100-mL double-jacketed glass cell. The titrating solution was added with the help of a microburette (ABU901) driven by an automatic

TABLE 1 Chemical Structures of the Ligands [32]

Compound	Structure.
L1	
L2	
L3	

titrator Tim 900 (Titralab 90), able to inject volumes as low as  $1 \mu\text{L}$ . The dynamic mode (variable addition of titrant, smaller in the steep equivalence regions) was used to establish the titration curve, the first derivative and to collect the numerical data. The logarithm of  $\text{H}^+$  concentration was measured with a combined glass electrode (filled with  $\text{NaCl}$  (0.01 M) +  $\text{NaClO}_4$  (0.09 M)) saturated with  $\text{AgCl}$  solution at the same ionic strength than the studied solution. This electrode was calibrated using the experimental law given in the following equation [33], where  $a$  and  $b$  are experimentally determined constants with HCl calibrations solutions ( $10^{-2}$  and  $10^{-3}$  M) with  $I = 0.1$  M ( $\text{NaClO}_4$ ):

$$\text{pH}_{\text{true}} = \text{pH}_{\text{read}} + a + b \cdot 10^{-\text{pH}_{\text{read}}}$$

All measurements were made in bidistilled water. The experimental values are the arithmetic mean resulting of five independent experiments. The Superquad [34] program was used for calculations of all protonation and stability constants. The distribution curves were drawn with Haltafall program [35].

### Determination of Equilibrium Constants

The overall apparent protonation constants  $\beta_i$  are relative to the equilibrium:

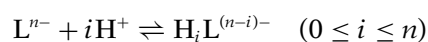

and they are defined according to Eq. (1):

$$\beta_i = [\text{H}_i\text{L}^{(n-i)-}] / [\text{H}^+]^i \cdot [\text{L}^{n-}] \quad (1)$$

They are linked to the stepwise protonation constants  $K_i$  (Eq. (2)):

$$K_i = \beta_i / \beta_{i-1} \quad (2)$$

and are obtained from acidity constants  $\text{p}K_a$

$$\log K_i = -\text{p}K_{a(n-i+1)} \quad (1 \leq i \leq n) \quad (3)$$

The apparent overall stability constants  $\beta_{xyz}$  of the complexes, corresponding to the following equilibrium:

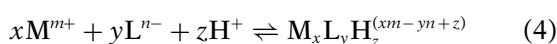

are given by the following equation:

$$\beta_{xyz} = [\text{M}_x\text{L}_y\text{H}_z^{(xm-yn+z)}] / [\text{M}^{m+}]^x [\text{L}^{n-}]^y [\text{H}^+]^z \quad (5)$$

where  $x$  pertains to metal (M),  $y$  to ligand (L), and  $z$  to proton; in the case of hydroxo species,  $z$  is negative.

## RESULTS AND DISCUSSION

### Compounds Acidity and Determination of their $\text{p}K_a$

The titration curves of the di, tri, and tetraphosphonic acid (L1, L2, and L3) with NaOH are given in Fig. 1.

First of all, there is a neat difference in the acidity of the three compounds showed by a decrease of pH values during titration. These values allow us to point out that the acidic power of these compounds

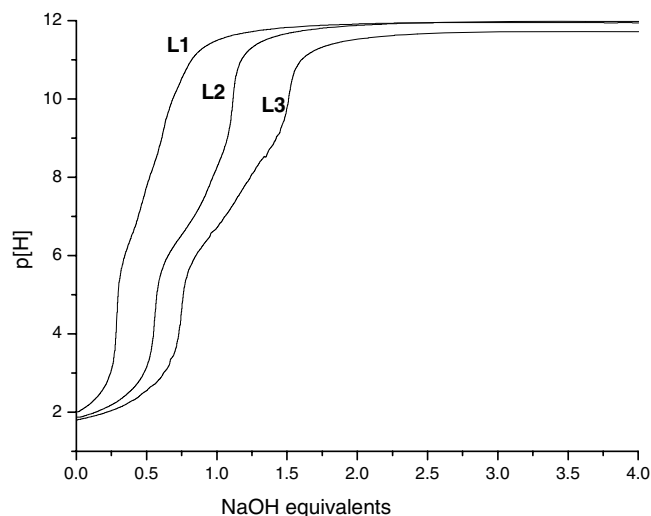

FIGURE 1 Titration curves of the acids ( $C_{\text{acids}} = 10^{-2}$  M,  $I = 0.1$  M,  $\text{NaClO}_4$ , and  $t = 25^\circ\text{C}$ ) in aqueous solution.

followed the sequence:  $\text{L1} > \text{L2} > \text{L3}$ . The values given by Superquad program [34] are the best fit between theoretical values derived from our models and the experimental data. The arithmetic mean of  $\text{p}K_{\text{ai}}$  values reported in Table 2 was determined through five independent experiments.

These values were used for the determination of the species distribution curves using the Haltafall program. The species distribution diagram as a function of pH (Fig. 2) shows that the deprotonation of L3 occurs at pH 0 and leads to the successive formation of different protonated species; the deprotonation is completed at  $\text{pH} > 10$ . Similar diagrams were obtained for L2 and L1.

### Deprotonation Process

Starting from the above-determined  $\text{p}K_{\text{ai}}$  values and using the method described by Chafaa et al. for related compounds, the deprotonation pathway of **3** is as follows (Scheme 1):

- The first step corresponds to the sum of the first two  $\text{p}K_a$  values of the ligand, according to the following equilibrium:  $\text{H}_{10}\text{L} \rightleftharpoons \text{H}_8\text{L}^{2-} + 2\text{H}^+$ .
- The second and the third steps are the first deprotonation of the two other phosphonic acid groups with  $\text{p}K_a = 2.10$  and  $2.26$ , respectively. The difference between these two values is not significant and characterizes the same acidity, because of the symmetry of the molecule. This fact can occur only when the involved protons belong to two aromatic rings and are located at the same position on these rings. So, each phosphonic acid group has lost one proton and the anion  $\text{H}_6\text{L}^{4-}$  remains symmetrical.
- The fourth step leads to the deprotonation of one of the phosphonate groups (second OH function of the starting phosphonic acid) from the tetravalent anion. The  $\text{p}K_a$  value ( $3.26$ ) is very weak compared to the second acidity of the orthophosphoric acid ( $\text{p}K_a = 7.2$ ) because of the strong protonation of this anion  $\text{H}_6\text{L}^{4-}$ .
- In the fifth step occurs the deprotonation of the second phosphonate group located on the same aromatic ring. This pathway could justify the jump of the  $\text{p}K_a$  values from  $3.26$  to  $6.14$ .
- The sixth and the seventh steps correspond to the deprotonation of the last two OH groups from each remaining phosphonate group on the second aromatic ring. The negative charges of the obtained anions ( $-7$  and  $-8$ ) lead to a less easy deprotonation, with  $\text{p}K_a$  values of  $6.54$  and  $7.42$ , respectively.

**TABLE 2**  $pK_{ai}$  Values for the Different Acidities in Aqueous Solution ( $C_{acid} = 10^{-2}$  M,  $I = 0.1$  M NaClO<sub>4</sub>, and  $t = 25^{\circ}\text{C}$ )

Compound	Species	$\log \beta_{ai}$	$pK_{ai}$	pH Range
L1	H <sub>6</sub> L1/H <sub>5</sub> L1 <sup>-</sup>	38.70 ± 0.07	2.12	2.00–11.00
	H <sub>5</sub> L1 <sup>-</sup> /H <sub>4</sub> L1 <sup>2-</sup>	36.58 ± 0.04	2.39	
	H <sub>4</sub> L1 <sup>2-</sup> /H <sub>3</sub> L1 <sup>3-</sup>	34.19 ± 0.03	6.13	
	H <sub>3</sub> L1 <sup>3-</sup> /H <sub>2</sub> L1 <sup>4-</sup>	28.06 ± 0.03	7.67	
	H <sub>2</sub> L1 <sup>4-</sup> /HL1 <sup>5-</sup>	20.39 ± 0.02	9.51	
	HL1 <sup>5-</sup> /L1 <sup>6-</sup>	10.88 ± 0.02	10.88	
L2	H <sub>8</sub> L2/H <sub>7</sub> L2 <sup>-</sup>	38.01 ± 0.01	1.94	1.85–9.50
	H <sub>7</sub> L2 <sup>-</sup> /H <sub>6</sub> L2 <sup>2-</sup>	36.06 ± 0.01	1.94	
	H <sub>6</sub> L2 <sup>2-</sup> /H <sub>5</sub> L2 <sup>3-</sup>	34.11 ± 0.03	2.20	
	H <sub>5</sub> L2 <sup>3-</sup> /H <sub>4</sub> L2 <sup>4-</sup>	32.09 ± 0.02	2.98	
	H <sub>4</sub> L2 <sup>4-</sup> /H <sub>3</sub> L2 <sup>5-</sup>	29.12 ± 0.02	6.16	
	H <sub>3</sub> L2 <sup>5-</sup> /H <sub>2</sub> L2 <sup>6-</sup>	22.96 ± 0.02	6.54	
	H <sub>2</sub> L2 <sup>6-</sup> /HL2 <sup>7-</sup>	16.42 ± 0.02	7.57	
	HL2 <sup>7-</sup> /L2 <sup>8-</sup>	8.85 ± 0.02	8.85	
L3	H <sub>10</sub> L3/H <sub>9</sub> L3 <sup>-</sup>	48.48 ± 0.03	1.77	1.70–10.00
	H <sub>9</sub> L3 <sup>-</sup> /H <sub>8</sub> L3 <sup>2-</sup>	46.64 ± 0.03	1.77	
	H <sub>8</sub> L3 <sup>2-</sup> /H <sub>7</sub> L3 <sup>3-</sup>	44.94 ± 0.03	2.10	
	H <sub>7</sub> L3 <sup>3-</sup> /H <sub>6</sub> L3 <sup>4-</sup>	42.86 ± 0.03	2.26	
	H <sub>6</sub> L3 <sup>4-</sup> /H <sub>5</sub> L3 <sup>5-</sup>	40.60 ± 0.02	3.26	
	H <sub>5</sub> L3 <sup>5-</sup> /H <sub>4</sub> L3 <sup>6-</sup>	37.34 ± 0.02	6.14	
	H <sub>4</sub> L3 <sup>6-</sup> /H <sub>3</sub> L3 <sup>7-</sup>	31.20 ± 0.02	6.54	
	H <sub>3</sub> L3 <sup>7-</sup> /H <sub>2</sub> L3 <sup>8-</sup>	24.66 ± 0.02	7.42	
	H <sub>2</sub> L3 <sup>8-</sup> /HL3 <sup>9-</sup>	17.24 ± 0.02	8.38	
	HL3 <sup>9-</sup> /L3 <sup>10-</sup>	8.92 ± 0.01	8.92	

- At last, the eighth and the ninth steps are due to the deprotonation of the two phenolic groups successively with 8.38 and 8.92  $pK_a$  values, respectively.

The behavior of the asymmetric compound L2 is the same than in the case of L3. The three first  $pK_a$  values are slightly higher than those of L3 but remain in the same order of magnitude. This corresponds

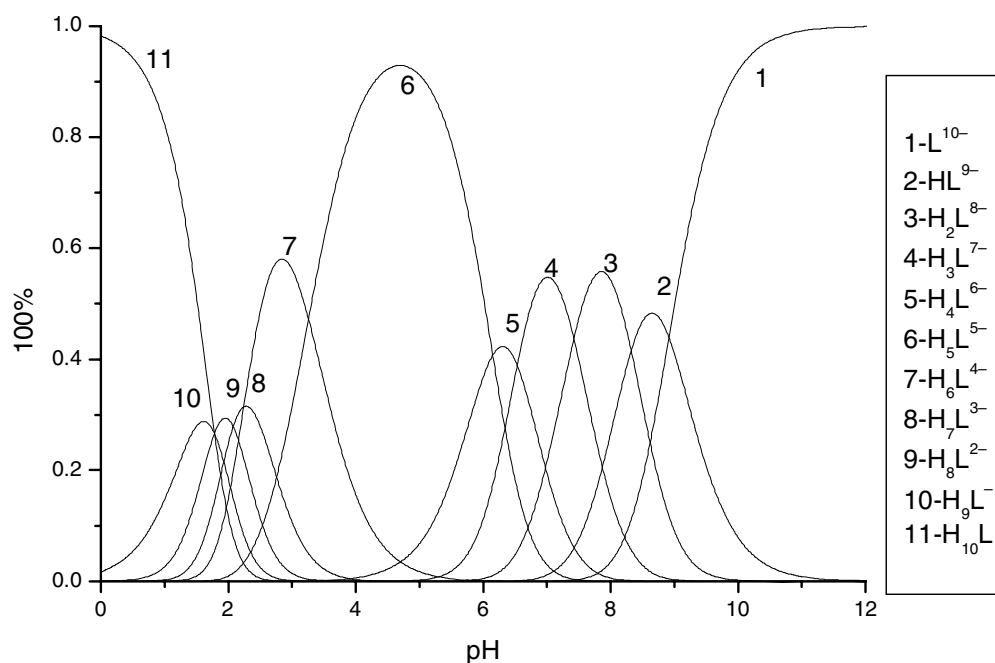
**FIGURE 2** Distribution curves of different acids species of the ligand L3 ( $C_{acids} = 10^{-2}$  M,  $I = 0.1$  M, NaClO<sub>4</sub>, and  $t = 25^{\circ}\text{C}$ ).

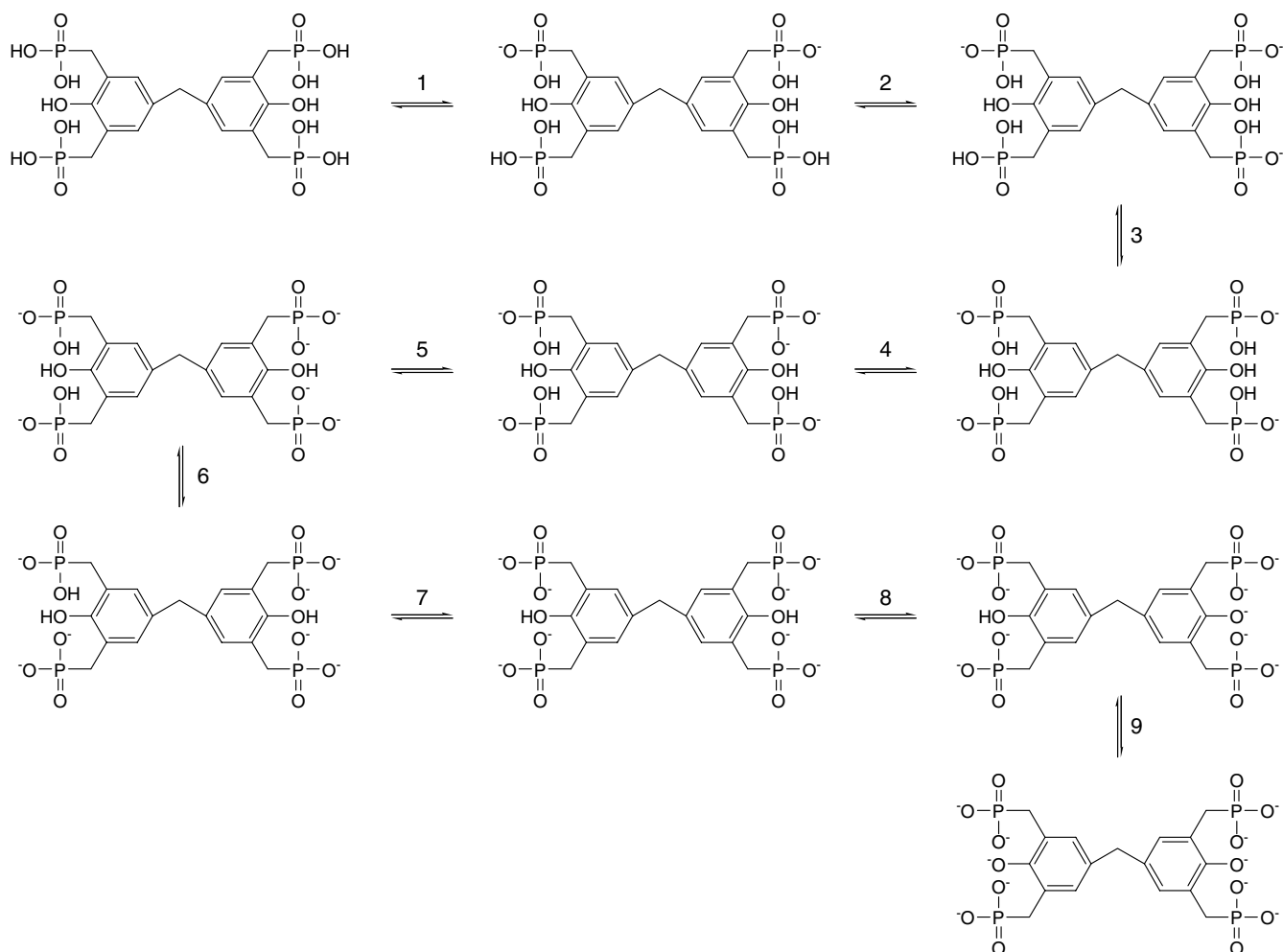

SCHEME 1

to the first deprotonation of each phosphonic acid group. The  $pK_a = 2.98$  for the fourth deprotonation is quite identical to the value obtained for the fifth deprotonation of L3. The last two constants relative to the phosphonic acid groups are the same for the two acids. Finally, the  $pK_a$  values for the phenolic groups are quite identical even though the first one is lower (7.57 instead of 8.38). The first two acidities for compound L1 are slightly higher (2.12 and 2.39, respectively) than those of the two preceding compounds. The second deprotonation of each phosphonic acid group leads to  $pK_a$  values of 6.13 and 7.67, respectively. These values are close to those of orthophosphoric acid and higher than in the cases of the two other compounds. Finally, the phenolic group on the ring bearing phosphonate groups exhibits a  $pK_a$  value of 9.51 whereas the last phenolic function has a  $pK_a = 10.88$ , slightly higher than the phenol itself (9.9). These results show that the acidic potency decreases in the following order: L3 > L2 > L1.

The comparison of these results with those obtained with 2-hydroxy 5-methyl phenyl 1,3-dimethylphosphonic acid [25] ( $pK_{a1} = 1.46$ ,  $pK_{a2} = 2.47$ ,  $pK_{a3} = 6.51$ ,  $pK_{a4} = 8.31$ ,  $pK_{a5} = 11.88$ ) indicates that these values are higher ( $pK_{a1}$  excepted) than those given in this paper. This shows that our ligands, with two aromatic moieties, are very powerful acids.

## STUDY OF THE COMPLEXATION OF METAL CATIONS

### Fe(III) Complexes

The titration curves of the ligand L3 alone and in the presence of Fe(III) are given in Fig. 3. The pH values at the beginning and along the titration are lower with Fe(III) than in the case of the free ligand. This suggests that the complex formation occurs through a competition reaction between iron ions and ligand

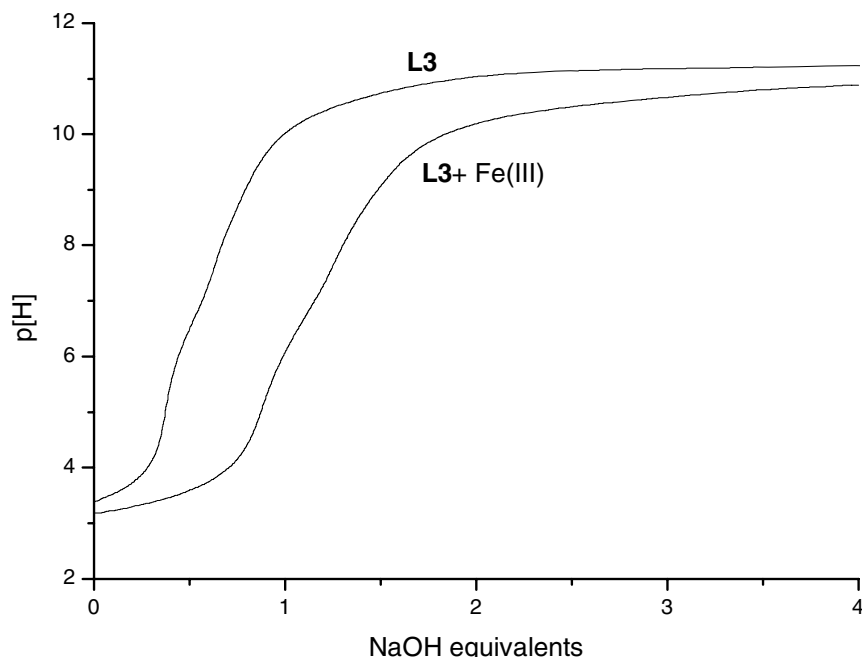

FIGURE 3 Titration curves of the ligand L3 with and without Fe(III).

protons. This is due to the formation of hydroxylated species in the presence of sodium hydroxide excess. Similar curves were obtained for L2 and L1 (not shown).

The treatment of the potentiometric data with Superquad program [34] starting from different systems allows us to determine the nature of the Fe(III) complexes in solution and their stability constants. The calculated apparent overall stability constants  $\beta_{xyz}$  are listed in Table 3.

All complexes correspond to a 1:1 metal to ligand molar ratio. The ligands L3, L2, and L1 lead to 10, 6, and 5 complex species, respectively. Among them, two hydroxylated compounds (with one and two  $\text{OH}^-$ , respectively) appear in the cases of the two last ligands. In the case of the first one, there is only one hydroxylated species:  $[\text{FeL1}(\text{OH})]^{4-}$ . The decreasing order for stability constants of nonprotonated complexes is  $[\text{FeL1}]^{3-} > [\text{FeL2}]^{5-} > [\text{FeL3}]^{7-}$ . This may be explained by the steric hindrance due to the presence of 2, 3, and 4 phosphonates groups, respectively. The decimal logarithm of the stability constant for  $[\text{FeL2}]^{5-}$  and  $[\text{FeL3}]^{7-}$  is 8.00, but for the ligand L1 this value is nearly 9.00. This result is explained by the charge effect: The negative charge becomes higher and higher along this series.

Starting from the values reported in Table 3 and protonation constants of the free ligands, it is possible to determine the protonation constants of the

complexes and calculated values of  $\log \beta_{1iz}$  are presented in Table 4.

Whatever the number of bounded protons, the overall protonation constants are always higher for

TABLE 3 Stability Constants for Fe(III) Complexes. ( $C_{\text{ligand}} = C_{\text{Metal}} 10^{-4} \text{ M}$ ,  $I = 0.1 \text{ M NaClO}_4$ , and  $t = 25^\circ \text{C}$ )

Ligand	Species	$\log \beta_{1iz}$	pH Range
L1	$[\text{FeL1}]^{3-}$	$8.99 \pm 0.01$	3.2–9.3
	$[\text{FeL1H}]^{2-}$	$18.14 \pm 0.01$	
	$[\text{FeL1H}_2]^{-}$	$26.15 \pm 0.01$	
	$[\text{FeL1H}_3]$	$32.42 \pm 0.01$	
	$[\text{FeL1}(\text{OH})]^{4-}$	$-0.53 \pm 0.01$	
L2	$[\text{FeL2}]^{5-}$	$8.12 \pm 0.01$	3.3–8.0
	$[\text{FeL2H}]^{4-}$	$15.59 \pm 0.01$	
	$[\text{FeL2H}_2]^{3-}$	$22.77 \pm 0.01$	
	$[\text{FeL2H}_3]^{2-}$	$28.20 \pm 0.01$	
	$[\text{FeL2}(\text{OH})]^{6-}$	$-0.90 \pm 0.13$	
	$[\text{FeL2}(\text{OH})_2]^{7-}$	$-10.55 \pm 0.12$	
	$[\text{FeL2H}_3]^{2-}$	$28.20 \pm 0.01$	
L3	$[\text{FeL3}]^{7-}$	$8.08 \pm 0.01$	3.5–10.2
	$[\text{FeL3H}]^{6-}$	$16.47 \pm 0.01$	
	$[\text{FeL3H}_2]^{5-}$	$23.88 \pm 0.01$	
	$[\text{FeL3H}_3]^{4-}$	$30.58 \pm 0.01$	
	$[\text{FeL3H}_4]^{3-}$	$36.63 \pm 0.01$	
	$[\text{FeL3H}_5]^{2-}$	$41.41 \pm 0.01$	
	$[\text{FeL3H}_6]^{-}$	$47.05 \pm 0.01$	
	$[\text{FeL3H}_7]$	$50.76 \pm 0.01$	
	$[\text{FeL3}(\text{OH})]^{8-}$	$-5.43 \pm 0.02$	
	$[\text{FeL3}(\text{OH})_2]^{9-}$	$-15.49 \pm 0.04$	

**TABLE 4** Protonation Constants for Fe(III) and Cu(II) Complexes

Metal	Ligand	log $\beta_{111}$	log $\beta_{112}$	log $\beta_{113}$	log $\beta_{114}$	log $\beta_{115}$	log $\beta_{116}$	log $\beta_{117}$
Fe(III)	L1	9.15	8.01	6.27	–	–	–	–
	L2	7.47	7.18	5.43	–	–	–	–
	L3	8.39	7.41	6.70	6.05	4.78	5.48	3.71
Cu(II)	L1	8.96	7.12	–	–	–	–	–
	L2	7.72	6.39	–	–	–	–	–
	L3	7.15	7.08	6.45	5.75	5.24	5.25	–

L1 and L2 than for L3. In all cases, the values of log  $\beta_{11z}$  diminish when passing from log  $\beta_{111}$  to log  $\beta_{115}$ . This fact was already observed and explained on the basis of charge effect [29,36].

The hydrolysis constants log  $\beta_{11-1}$  for Fe(III) complexes are  $-0.53$ ,  $-0.50$ , and  $-0.85$  for L1, L2, and L3, respectively. In the case of log  $\beta_{11-2}$ , the values are  $-9.83$  for L1 and  $-10.62$  for L3.

The complex species distribution curves from pH 1 to pH 12 or 14 are shown in Fig. 4. These curves are quite similar for L1 and L2. The order of predominance is the same:  $[\text{FeLH}_3]$ ,  $[\text{FeLH}_2]$ ,  $[\text{FeLH}]$ , and  $[\text{FeL}]$ , respectively, but the pH values for their maxima are slightly different. In both cases, the complexation of the  $\text{Fe}^{3+}$  occurs very soon at the initial pH value. The complex with the higher hydroxyl ions reaches 100% at pH 11.

In the case of L3, the Fe(III) cation is quickly coordinated and its percentage is near zero at pH 2. In the meantime, the first complex compound  $[\text{FeL3H}_7]$  is more stable with a 95% formation at pH 1.83. So, this ligand will be able to complex Fe(III) ions at this pH value without competitive species. Starting from pH 4, various complexes from  $[\text{FeL3H}_6]^-$  to  $[\text{FeL3H}]^{6-}$  appear successively until pH 9. In this case, the  $[\text{FeL3}]^{7-}$  complex is stable around pH 10.2. With the two other ligands, this species reaches its maximum at pH 9.4 (L1) and 8.2 (L2). Finally, formation of  $[\text{FeL3}(\text{OH})_2]^{9-}$  is completed at pH values higher than 13.

Some authors have shown that it is useful to take into account both soluble and insoluble hydroxylated species for trivalent metal ions as they can modify the complexation reactions [37]. But, in all cases, with a 1:1 molar ratio, we have not observed any insoluble species up to pH 13. Our polyphosphonic ligands show a higher complexing power than aliphatic ones [38].

### Cu(II) Complexes

The titration curves of the ligand L3 are given in Fig. 5. They show lower pH values with Cu(II) than in the case of the ligand alone. This is typical of stable

complexes: as the metal binds to the various anionic forms of the ligand, protons are released into the solution and then the pH diminishes. The pH values remain lower after the equivalence point, and this fact corresponds to the formation of hydroxylated complexes as observed with Fe(III). Similar curves were obtained for the two other systems.

The overall stability constants  $\beta_{11z}$  of Cu(II) complexes are given in Table 5. They were determined in the same way than with Fe(III). The ligands L3, L2, and L1 lead to 9, 4, and 4 complex species, respectively for pH < 10. The ligands L1 and L2 give one hydroxylated compound: the first ligand with one  $\text{OH}^-$  and the second two  $\text{OH}^-$ . In the case of L3, two hydroxylated complexes are obtained:  $[\text{CuL3}(\text{OH})]^{9-}$  and  $[\text{CuL3}(\text{OH})_2]^{10-}$ .

The stability order for nonprotonated complexes is  $[\text{CuL1}]^{4-} > [\text{CuL3}]^{8-} > [\text{CuL2}]^{6-}$ . The ligands L1 and L3 with a symmetrical structure favored square planar complexes. In the case of L2, the third phosphonic group leads to unsymmetrical ligand and the

**TABLE 5** Stability Constants for Cu(II) Complexes. ( $C_{\text{ligand}} = C_{\text{Metal}} = 10^{-4}$  M,  $I = 0.1$  M,  $\text{NaClO}_4$ , and  $t = 25^\circ\text{C}$ )

Ligands	Species	log $\beta_{11i}$	pH Range
L1	$[\text{CuL1}]^{4-}$	$11.51 \pm 0.01$	3.75–10.03
	$[\text{CuL1H}]^{3-}$	$20.47 \pm 0.01$	
	$[\text{CuL1H}_2]^{2-}$	$27.59 \pm 0.01$	
	$[\text{CuL1}(\text{OH})]^{5-}$	$-0.53 \pm 0.01$	
L2	$[\text{CuL2}]^{6-}$	$8.03 \pm 0.06$	3.61–9.30
	$[\text{CuL2H}]^{5-}$	$15.75 \pm 0.03$	
	$[\text{CuL2H}_2]^{4-}$	$22.14 \pm 0.03$	
	$[\text{CuL2}(\text{OH})_2]^{8-}$	$-11.23 \pm 0.12$	
L3	$[\text{CuL3}]^{8-}$	$10.68 \pm 0.06$	3.44–8.50
	$[\text{CuL3H}]^{7-}$	$17.83 \pm 0.06$	
	$[\text{CuL3H}_2]^{6-}$	$24.91 \pm 0.06$	
	$[\text{CuL3H}_3]^{5-}$	$31.36 \pm 0.17$	
	$[\text{CuL3H}_4]^{4-}$	$37.11 \pm 0.11$	
	$[\text{CuL3H}_5]^{3-}$	$42.35 \pm 0.06$	
	$[\text{CuL3H}_6]^{2-}$	$47.60 \pm 0.12$	
	$[\text{CuL3}(\text{OH})]^{9-}$	$-0.67 \pm 0.15$	
$[\text{CuL3}(\text{OH})_2]^{10-}$	$-6.00 \pm 0.15$		



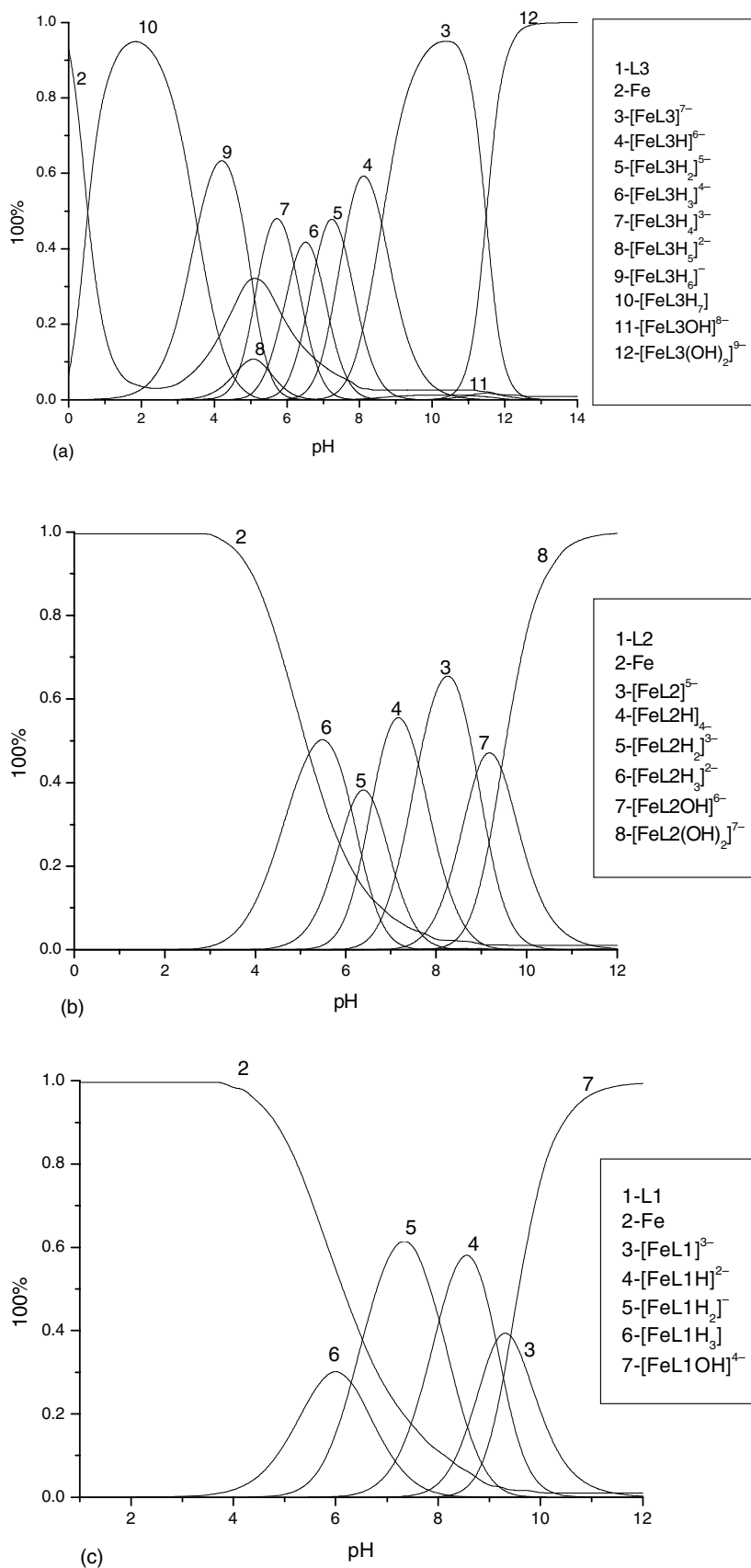

FIGURE 4 Species distribution for Fe(III) complexes with L3 (a), L2 (b), and L1 (c).

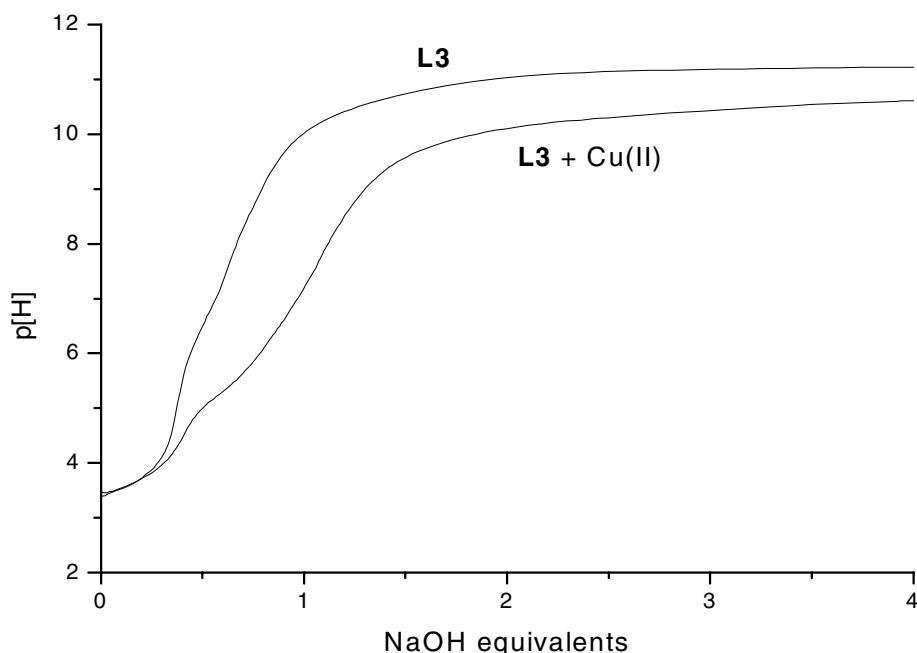

FIGURE 5 Titration curves of the ligand L3 with and without Cu(II).

stability constant of the first complex is lower than with the symmetrical ones. As it has been observed with Fe(III) compounds, the higher stability is obtained with the ligand L1. The complex  $[\text{CuL3}]^{8-}$  is more stable than  $[\text{CuL2}]^{6-}$ , whereas  $[\text{FeL1}]^{5-}$  is more stable than  $[\text{FeL3}]^{7-}$ . This change is due to the ability of Cu(II) to coordinate in a square planar geometry in the cases of symmetrical ligands like L1 and L3. Finally, these stability constants follow the Irving–Williams series [39,40], with higher stability for Cu(II) complexes than for iron complexes.

The protonation constants of the Cu(II) complexes are reported in Table 4. The values of  $\log \beta_{111}$  and  $\log \beta_{112}$  are lower for L2 than for L1 and L3.

The distribution curves for Cu(II) complexes are given in Fig. 6. As it has been observed for iron complexes, it is possible to obtain complex species with a high yield for determined pH ranges. In the 0–4 pH range, the ligands L1 and L2 remain stable and the complexation occurs starting from pH 4 but the yields are not so high than is the case of Fe(III) compounds. The third ligand L3 shows another behavior. From pH 1.38 to pH 5.25, the main complex species is  $[\text{CuL3H}_6]^{2-}$  with nearly 100% yield. It starts to decompose for  $\text{pH} > 3$ , giving first free Cu(II) ions and second new complexes such as  $[\text{CuL3H}_3]^{5-}$ ,  $[\text{CuL3H}_4]^{4-}$ ,  $[\text{CuL3H}_5]^{3-}$ , and  $[\text{CuL3H}_6]^{2-}$ . In alkaline medium, two complexes are mainly obtained:  $[\text{CuL3}]^{8-}$  (80% at pH 8) and  $[\text{CuL3}(\text{OH})_2]^{11-}$ , which is the only stable complex

compound starting from pH 10. As reported for simple diposphonic acids [41], we have not observed any insoluble hydroxylated species in aqueous solution.

TABLE 6 Stability Constants for Cu(II) Complexes with Various Phosphonic Acids

Ligands	Reference	Complex	$\log \beta$
4-Mono(dihydroxyphosphonyl) methyl phenol	[33]	ML	7.69
2,6-Bis(dihydroxyphosphonyl)methyl 4-methyl phenol	[28]	MLH	14.45
		ML	12.76
Ethylene diamine (tetramethylene phosphonic) acid	[42]	MLH	20.48
		ML	7.99
2-Mono(dihydroxyphosphonyl) methyl phenol	[27]	ML	11.50
1-Phenyl-1-hydroxymethylene bisphosphonate	[43]	ML	10.98
1-Phenyl-1-hydroxymethylene bisphosphonate diester	[43]	MLH	20.20
		ML	4.18

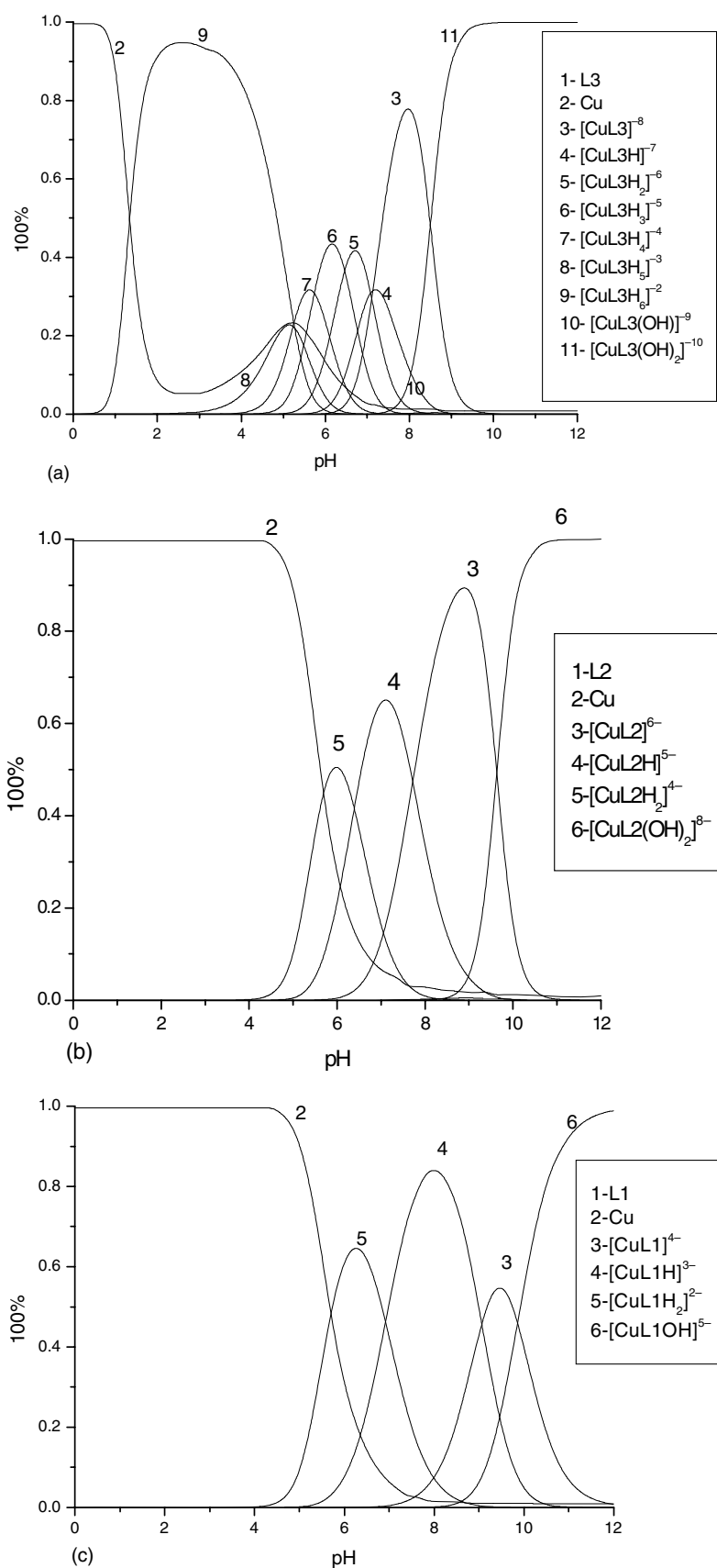

FIGURE 6 Species distribution for Cu(II) complexes with L3 (a), L2 (b), and L1 (c).

The presence of several phosphonic acid groups enhances the stability of the corresponding Cu(II) complexes. Some overall stability constants are given in Table 6. In all cases, the  $\log \beta$  values are higher with two phosphonic acid groups than with one group only. The three new ligands described in this paper appear to be better chelating agents, mainly L3 for which a very stable complex compound is obtained with high yield, even in acidic medium, with Fe(III) and Cu(II) ions.

In both cases, the protonation constants of the complexes decrease as the stability constant increase. A high stability constant corresponds to high coordination bond strength. So, when the metal ion is strongly bound to the ligand, the proton is not able to remove this cation and the protonation constant is feeble.

## CONCLUSION

These three new polyphosphonic acids, such as {methylenebis[(2-hydroxy-5,1,3-phenylene) bismethylene]} tetraphosphonic acid L3, {5-[4-hydroxy-3,5-bis(phosphonomethyl)benzyl]-2-hydroxybenzyl} phosphonic acid L2, and {[2-hydroxy-5-(4-hydroxybenzyl)-1,3-phenylene] bis(methylene)} bis(phosphonic acid) L1, were found to be very powerful acids and effective ligands for both Fe(III) and Cu(II) ions. The acidic properties decrease in the following order:  $H_{10}L3 > H_8L2 > H_6L1$ . Even in alkaline medium, there is only soluble species without any precipitation of the corresponding hydroxides. These ligands could be used to remove Fe(III) and Cu(II) ions from waste water for instance, because of their high affinity for Fe(III) and Cu(II) ions even at low or high pH values.

## REFERENCES

- [1] Gledhill, W. E.; Feitel, T. C. J. *The Handbook of Environmental Chemistry*; Springer: Berlin, 1992.
- [2] Landner, L.; Walterson, E. *Phosphonates Used for Detergent Applications*; Swedish Environmental Research Group (MFG): Stockholm, Sweden, 1993.
- [3] Jaworska, J.; Van-Genderen-Takken, H.; Hanstvert, A.; Plassche, E. V. d.; Feijtel, T. *Chemosphere* 2002, 47, 655–665.
- [4] Demadis, K. D.; Katarachia, S. D. *Phosphorus, Sulphur, Silicon Relat Elem* 2004, 179, 627–648.
- [5] Demadis, K. D.; Lykoudis, P. *Bioinorg Chem Appl* 2005, 3, 135.
- [6] Darling, D.; Rakshpal, R. *Mater Performance* 1998, 37, 42–45.
- [7] Andijani, L.; Turgoose, S. *Desalination* 1999, 123, 223–231.
- [8] Ramesh, S.; Rajeswari, S. *Corrosion Sci* 2004, 47, 151–169.
- [9] Demadis, K. D.; Barouda, E.; Raptis, R. G.; Zhao, H. *Inorg Chem* 2008, 48, 819–821.
- [10] Demadis, K. D.; Mantzaridis, C.; Raptis, R. G.; Mezei, G. *Inorg Chem* 2005, 44, 4469–4471.
- [11] Demadis, K. D.; Papadaki, M.; Raptis, R. G.; Zhao, H. *Chem Mater* 2008, 20, 4835–4846.
- [12] Holy, A.; Guenter, J.; Dvorakova, H.; Masojdkova, M.; Andrei, G.; Snoeck, R.; Balzarini, J.; De Clercq, E. *J Med Chem* 1999, 42, 2064–2086.
- [13] Grison, C.; Letondor, C.; Chibli, H.; Coutrot, P. *Tetrahedron Lett* 2005, 46, 6525–6528.
- [14] Naumann, C.; Yoshikawa, K.; Kitamura, K.; Inazu, M. 1996, p 16.
- [15] Crisponi, G.; Nurchi, V. M.; Silvagni, R.; Faa, G. *Polyhedron* 1999, 18, 3219–3226.
- [16] Hershko, C.; Pinson, A.; Link, G. *Acta Haematol* 1996, 95, 87–92.
- [17] Faa, G.; Crisponi, G. *Coord Chem Rev* 1999, 184, 291–310.
- [18] Westerback, S. S.; Rajan, K. S.; Martell, A. E. *J Am Chem Soc* 1965, 87, 2567–2572.
- [19] Chatterton, N.; Gateau, C.; Mazzanti, M.; Pécaut, J.; Borel, A.; Helm, L.; Merbach, A. *J Chem Soc, Dalton Trans* 2005, 1129–1135.
- [20] Sigel, H.; Sigel, A. *J Indian Chem Soc* 2000, 77, 501–509.
- [21] Fatemi, N.; Sarkar, B. *Inorg Chim Acta* 2002, 339, 179–187.
- [22] Barja, B. C.; Herszage, J.; Afonso, M. d. S. *Polyhedron* 2001, 20, 1821–1830.
- [23] Chruscinski, L.; Mlynarz, P.; Malinowska, K.; Ochocki, J.; Boduszek, B.; Kozlowski, H. *Inorg Chim Acta* 2000, 303, 47–53.
- [24] Fernandez-Botello; Holy, A.; Moreno, V.; Sigel, H. *J Inorg Biochem* 2004, 98, 2114–2124.
- [25] Bohmer, V.; Vogt, W.; Chafaa, S.; Meullemeestre, J.; Schwing, M. J.; Vierling, F. *Helv Chim Acta* 1993, 76, 139–149.
- [26] Chafaa, S.; Meullemeestre, J.; Schwing, M. J.; Vierling, F.; Bohmer, V. *Helv Chim Acta* 1993, 76, 1425–1434.
- [27] Chafaa, S. *Université Louis Pasteur, Strasbourg (France)*, 1993.
- [28] Benganem, F.; Chafaa, S.; Bouet, G.; Khan, M. A. *Phosphorus, Sulfur, Silicon, Relat Elem* 2001, 170, 159–169.
- [29] Bentouhami, E.; Bouet, G.; Khan, M. A. *Talanta* 2002, 57, 545–554.
- [30] Bentouhami, E.; Bouet, G.; Khan, M. A. *Phosphorus, Sulfur, Silicon, Relat Elem* 2003, 178, 903–921.
- [31] Bentouhami, E.; Bouet, G.; Schwing, M. J.; Khan, M. A. *J Sol Chem* 2006, 35, 889–916.
- [32] Aliouane, N.; Chafaa, S.; Douadi, T.; Hélesbeux, J. J.; Khan, M. A.; Bouet, G.; Duval, O. *Phosphorus, Sulfur, Silicon, Relat Elem*, submitted.
- [33] Haernger, M.; Schwing, J. P. *Bull Soc Chim Fr* 1967, 708.
- [34] Gans, P.; Sabatini, A.; Vacca, A. *J Chem Soc, Dalton Trans* 1985, 1195.
- [35] Ingri, N.; Kolowicz, W. K. A.; Sillen, L. G.; Warnquit, B. *Talanta* 1967, 14, 1261–1286.
- [36] Schwing, M.-J.; Chafaa, S.; Meullemeestre, J.; Vierling, F. *J Chem Res Synop* 1995, 6, 258–259.
- [37] Duffield, J. R.; Johns, J. R.; Marsicano, F.; Williams, D. R. *Polyhedron* 1991, 10, 1121–1129.

- [38] Lacour, S.; Deluchat, V.; Bollinger, J. C.; Serpaud, B. *Talanta* 1998, 46, 999–1009.
- [39] Irving, H.; Williams, R. J. P. *J Chem Soc* 1950, 2890–2892.
- [40] Khan, M. A.; Bouet, G.; Vierling, F.; Meullemeestre, J.; Schwing, M. J. *Transit Met Chem* 1996, 21, 231–234.
- [41] Bouhsina, S.; Buglyó, P.; Abi Aad, E.; Aboukais, A.; Kiss, T. *Inorg Chim Acta* 2004, 357, 305–310.
- [42] Motekaitis, R. J.; Murase, I.; Martell, A. E. *J Inorg Nucl Chem* 1971, 7, 3353–3365.
- [43] Gumienna-Kontecka, E.; Jezierska, J.; Lecouvey, M.; Leroux, Y.; Koslowski, H. *J Inorg Biochem* 2002, 89, 13–17.