



HAL
open science

Radical cation salts of TTF donors with XF₆ (X = Re, Ta) anions

Cécile Mézière, Magali Allain, Flavia Pop, Kasper Pedersen, Rodolphe Clérac, Pascale Auban-Senzier, Jesper Bendix, Narcis Avarvari

► **To cite this version:**

Cécile Mézière, Magali Allain, Flavia Pop, Kasper Pedersen, Rodolphe Clérac, et al.. Radical cation salts of TTF donors with XF₆ (X = Re, Ta) anions. Journées scientifiques 2017 SCF-BPL, 2017, Le Mans, France. , 2017. hal-02564431

HAL Id: hal-02564431

<https://univ-angers.hal.science/hal-02564431v1>

Submitted on 5 May 2020

HAL is a multi-disciplinary open access archive for the deposit and dissemination of scientific research documents, whether they are published or not. The documents may come from teaching and research institutions in France or abroad, or from public or private research centers.

L'archive ouverte pluridisciplinaire **HAL**, est destinée au dépôt et à la diffusion de documents scientifiques de niveau recherche, publiés ou non, émanant des établissements d'enseignement et de recherche français ou étrangers, des laboratoires publics ou privés.

Cécile Mézière¹, Magali Allain¹, Flavia Pop¹, Kasper Pedersen², Rodolphe Clérac², Pascale Auban Senzier³, Jesper Bendix⁴, Narcis Avarvari¹

¹Laboratoire MOLTECH-Anjou, UMR6200 CNRS-Université d'Angers, Faculté des Sciences, Bât. K, 2 Bd Lavoisier, 49045 Angers Cedex, France

²Centre de Recherche Paul Pascal, UPR CNRS 8641, Equipe "Matériaux Moléculaires & Magnétisme" (M3), 115 avenue du Dr. A. Schweitzer, 33600 Pessac, France

³Laboratoire de Physique des Solides, UMR8502 CNRS-Université Paris Sud, Bât. 510, 1 rue Nicolas Appert, 91405 Orsay Cedex, France

⁴Department of chemistry, Bât. B208, University park 5, 2100 Copenhagen, Denmark

Electrocrystallization set up [1]

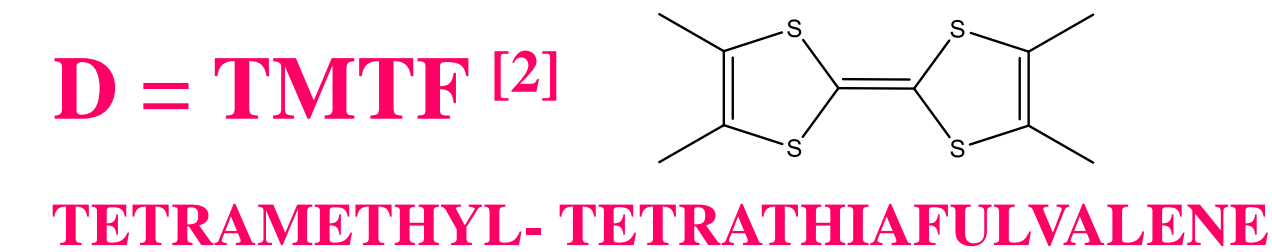
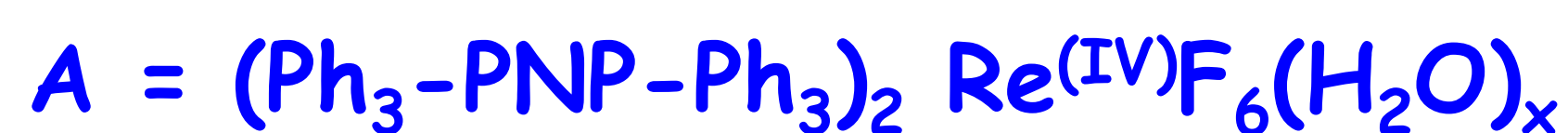
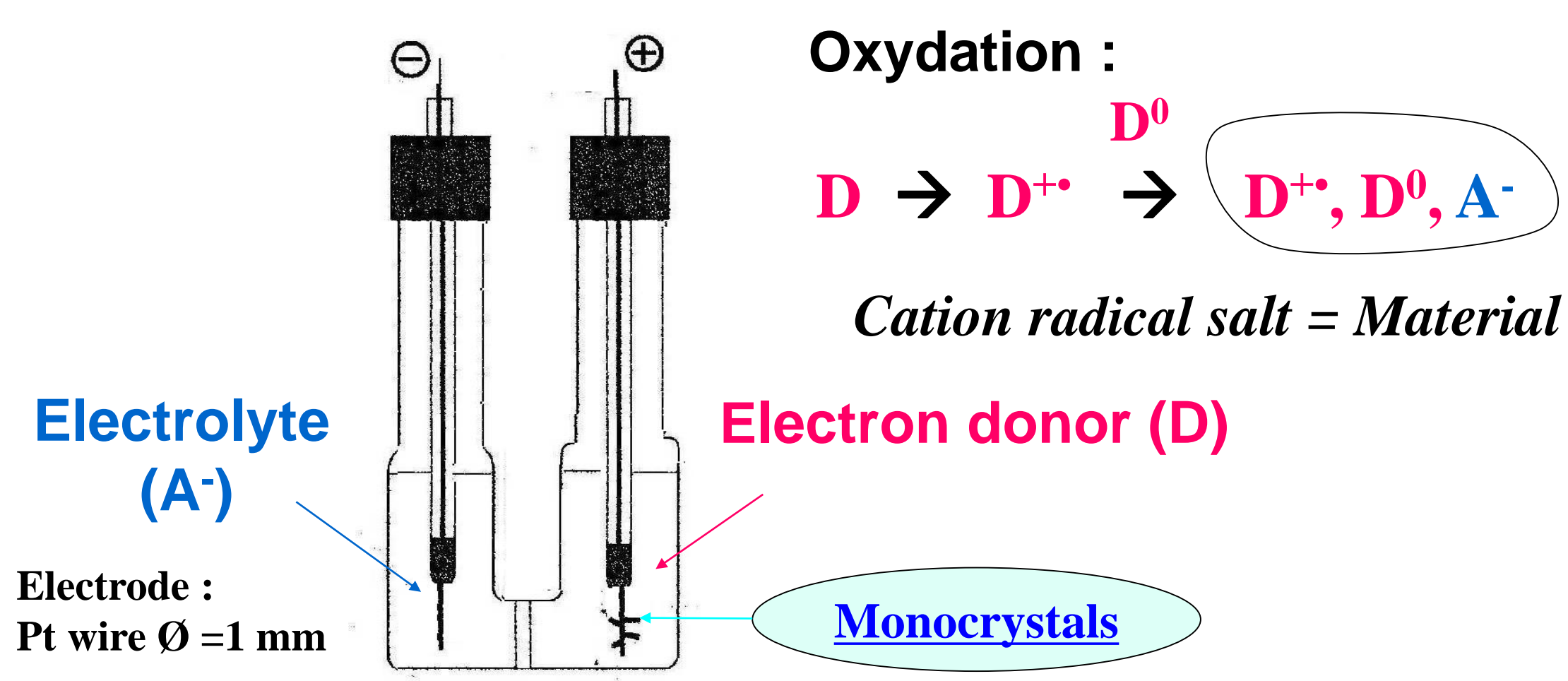

Solvent : $\text{CH}_3\text{CN}/1.1.2 \text{ TCE } 11/1 \text{ mL}$
 $T = 3^\circ \text{ C}, I = 1 \text{ to } 5 \mu\text{A}$



Unit cell, RT, $\lambda = 1.540598$:
 $a = 7.9941(17)\text{Å}$ $\alpha = 79.85(2)^\circ$
 $b = 8.121(2)\text{Å}$ $\beta = 89.145(18)^\circ$
 $c = 11.372(3)\text{Å}$ $\gamma = 65.466(18)^\circ$
 $V = 659.71(30) \text{Å}^3$
Triclinic system, P-1

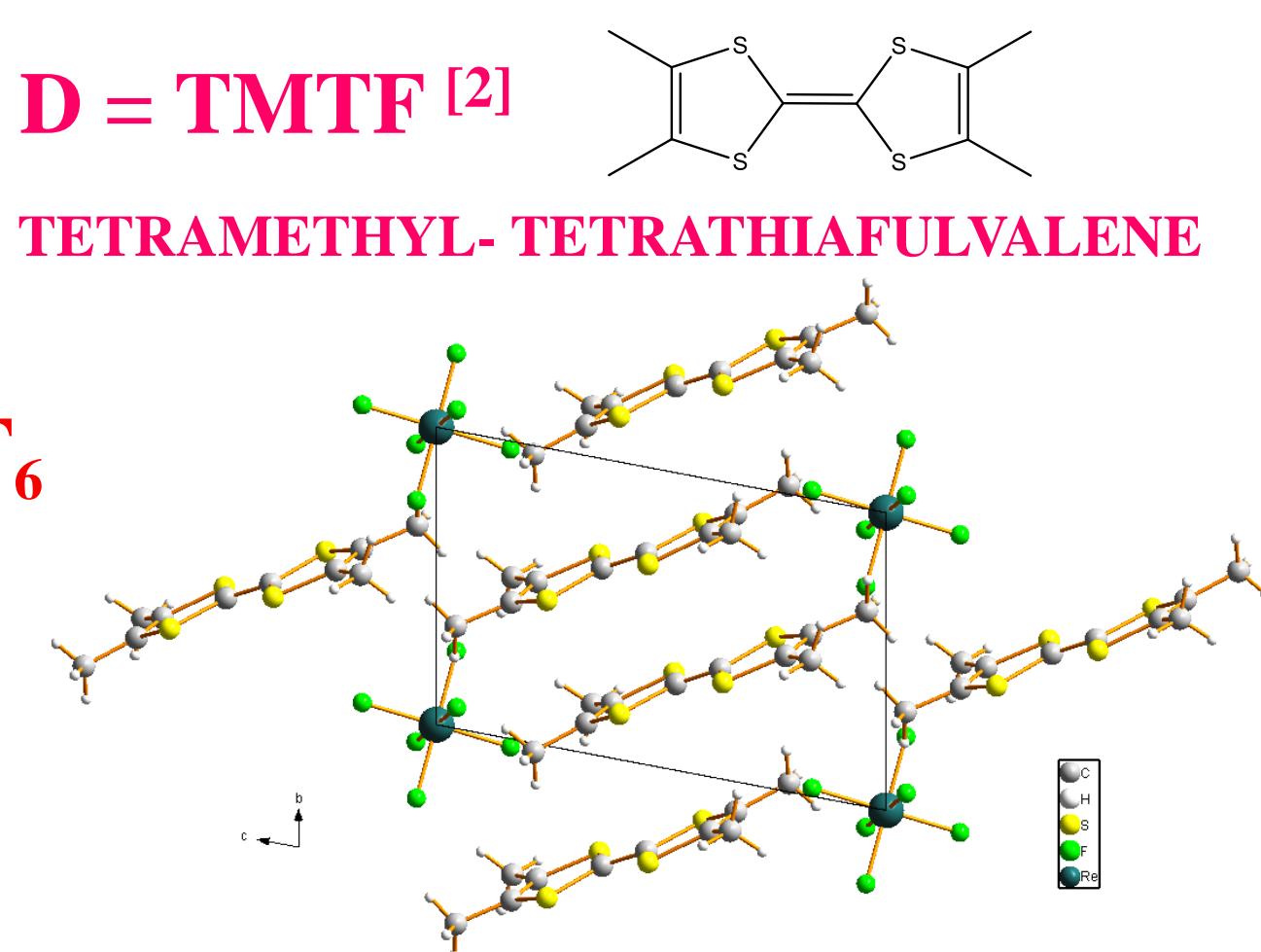
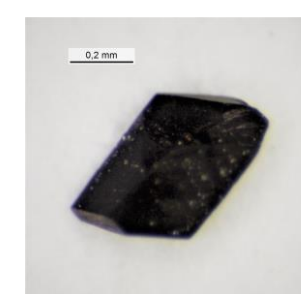

Strong dimerization \rightarrow insulating 1D system

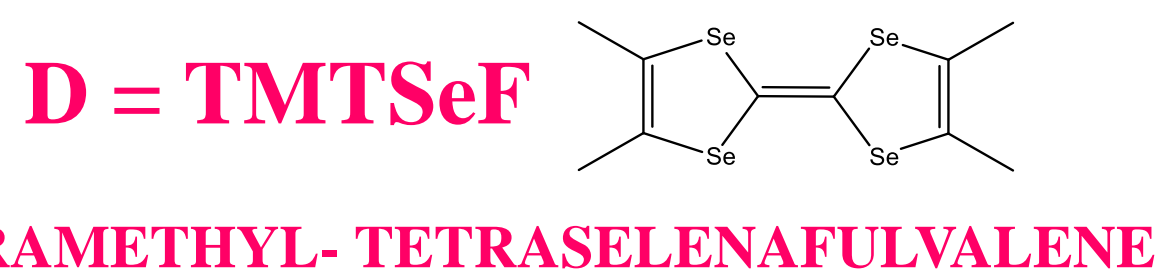
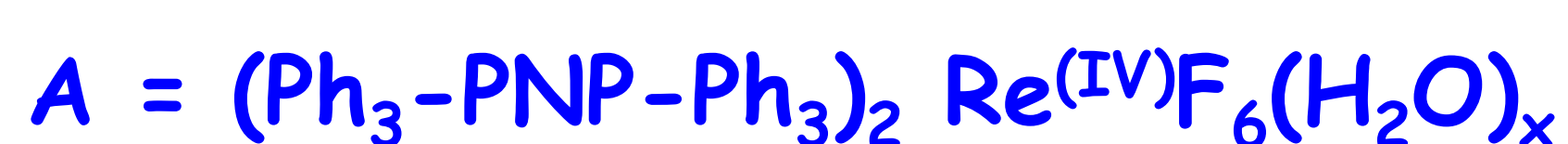

1) Solvent : $\text{CH}_3\text{CN}/1.1.2 \text{ TCE } 11/1 \text{ mL}$ \rightarrow 2 PHASES IN THE SAME CELL
 $T = 3^\circ \text{ C}, I = 1 \text{ to } 5 \mu\text{A}$

$(\text{TMTSeF})_3\text{Re}^{\text{IV}}\text{F}_4\text{Cl}_2$

Prisms

Unit cell, $T = 150 \text{ K}$, $\lambda = 0.71073 \text{ Å}$:
 $a = 7.9969(7)\text{Å}$ $\alpha = 77.707(9)^\circ$
 $b = 11.072(1)\text{Å}$ $\beta = 75.377(7)^\circ$
 $c = 13.171(1)\text{Å}$ $\gamma = 73.42(1)^\circ$
 $V = 1068.9(2) \text{Å}^3$
 $R1 = 3.70\%$
Triclinic system, P-1

Re^{IV}-Hal bond lengths (Å) :
Re1-F(1) 1.953(3)
Re1-F(3) 1.951(3)
Re1-Cl(1) 2.3183(2)

Uniform stacking of oxydized TMTSeF molecules, isolated chains

+ $(\text{TMTSeF})_2\text{Re}^{\text{V}}\text{F}_6$: rhénium (IV) has been oxydized in rhénium (V)

Very small needles!

Unit cell, $T = 150 \text{ K}$, $\lambda = 0.71073 \text{ Å}$
 $a = 7.1590(8)\text{Å}$ $\alpha = 83.28(1)^\circ$
 $b = 7.741(1)\text{Å}$ $\beta = 87.15(1)^\circ$
 $c = 13.706(3)\text{Å}$ $\gamma = 70.19(1)^\circ$
 $V = 709.7(2) \text{Å}^3$
 $R1 = 2.63\%$
Triclinic, P-1

« Bechgaard » phase [3]

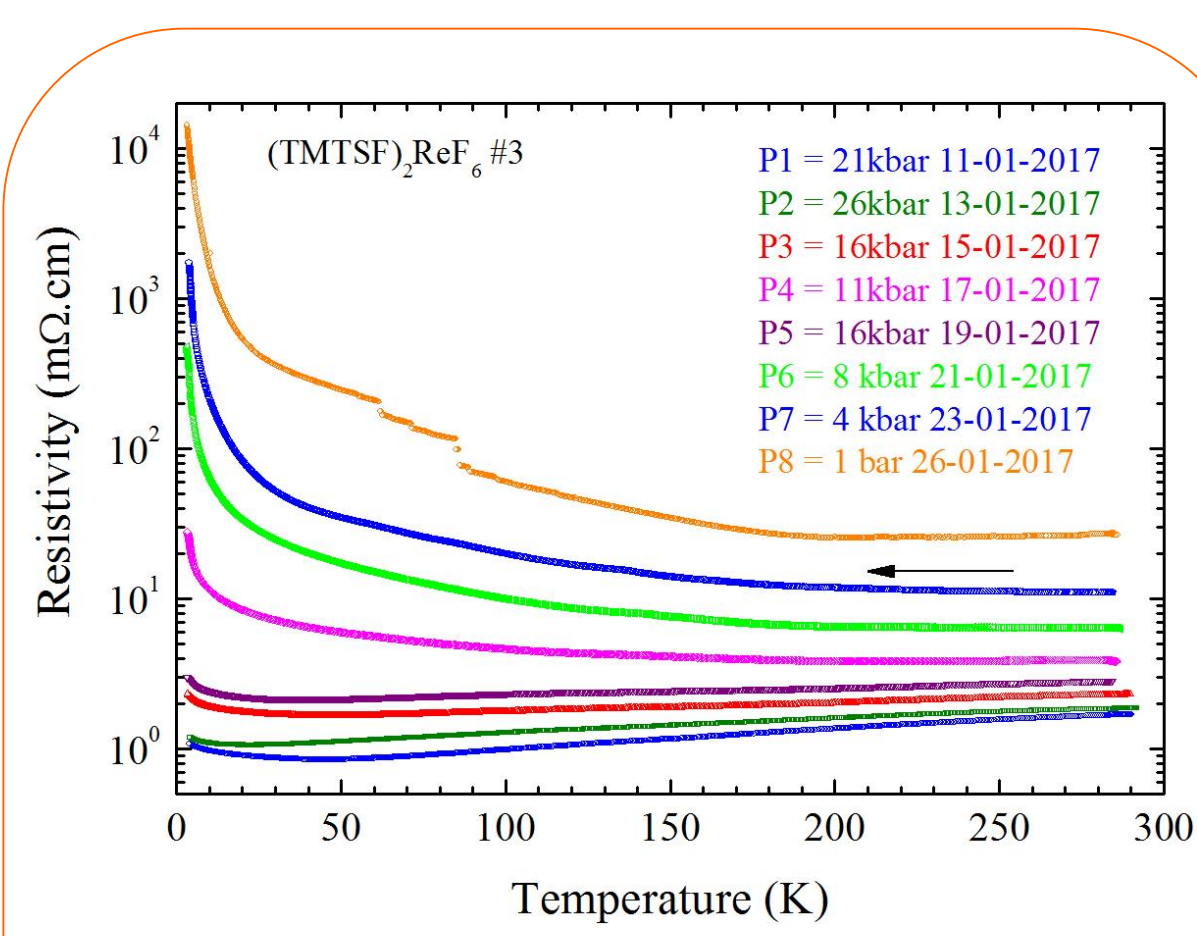

Re^V-F bond lengths (Å)
Re1-F(1A) 1.875(3)
Re1-F(1B) 1.88(2)
Re1-F(2A) 1.889(3)
Re1-F(2B) 1.796(18)
Re1-F(3) 1.870(3)

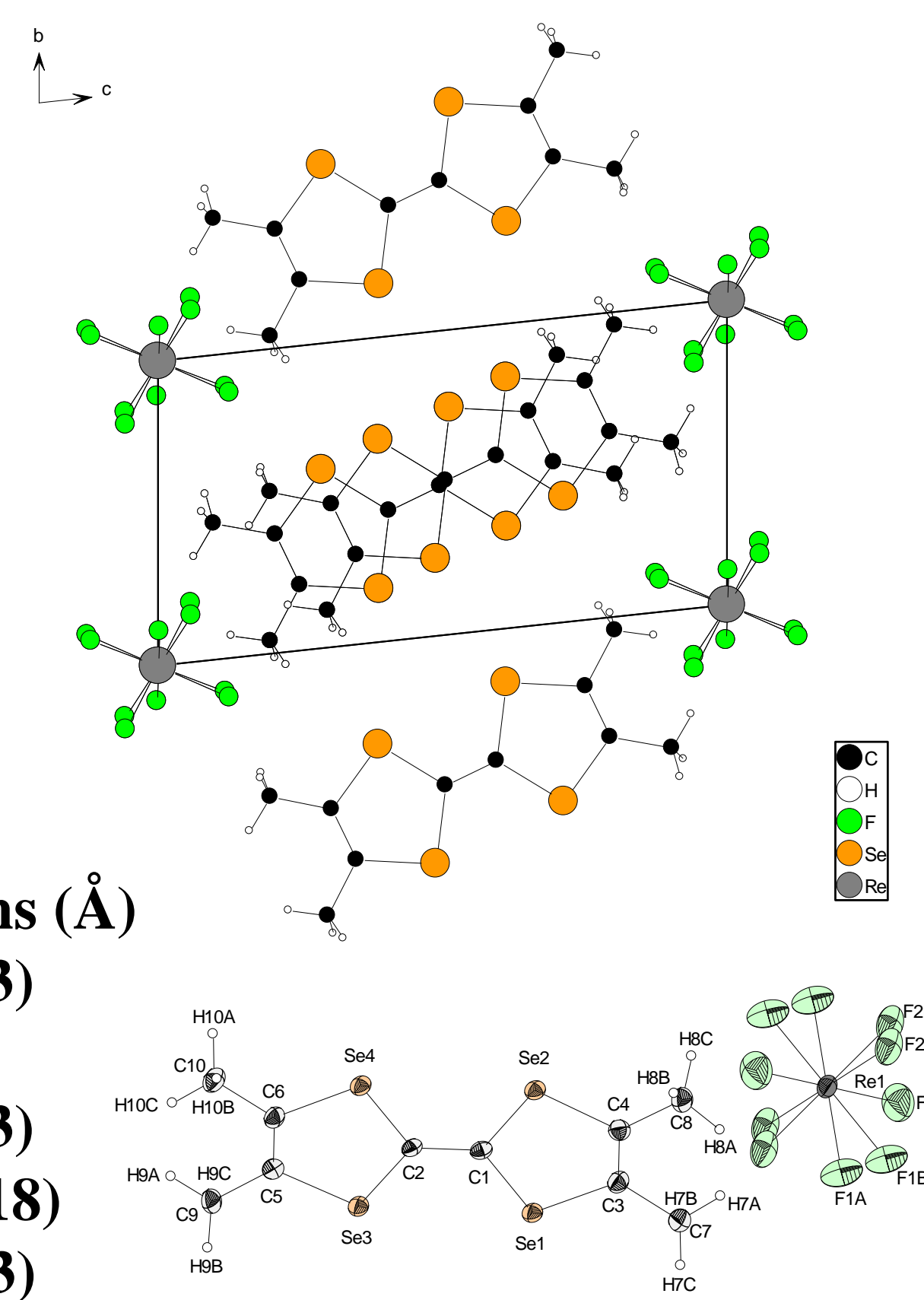

Unit cell at 100K : the disorder on F atoms disappears

Magnetism (R. Clérac) : measurements in progress

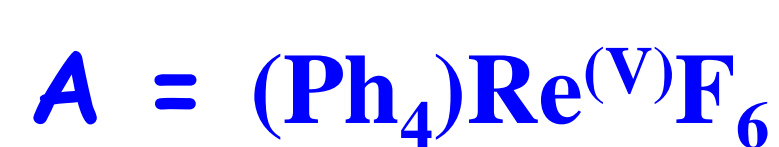

Larger needles

2) Solvent : $\text{CH}_3\text{CN}/1.1.2 \text{ TCE } 11/1$
 $T = 20^\circ \text{ C}, I = 0.5 \mu\text{A}$ \rightarrow Only the $(\text{TMTSeF})_2\text{Re}^{\text{V}}\text{F}_6$ phase

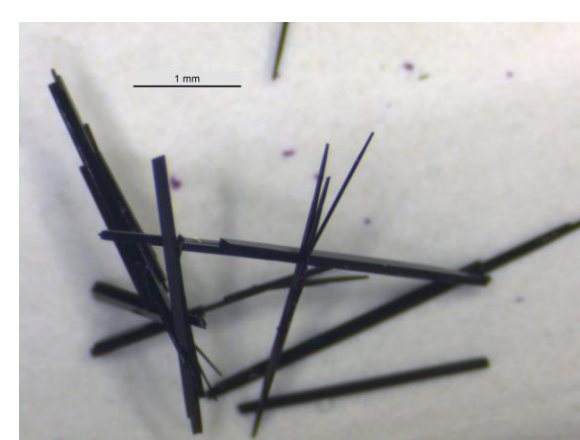

Attempts to synthesize the $(\text{TMTTF})_2\text{Re}^{\text{V}}\text{F}_6$ salt : do not work, TMTTF is immediatly oxydized by Re(V)

$\text{A} = \text{TBATa}^{\text{V}}\text{F}_6 \Rightarrow$ Diamagnetism/probe



Unit cell, $T = 150 \text{ K}$, $\lambda = 0.71073 \text{ Å}$
 $a = 7.7344(7)\text{Å}$ $\alpha = 92.376(5)^\circ$
 $b = 10.8408(8)\text{Å}$ $\beta = 98.270(6)^\circ$
 $c = 13.6409(9)\text{Å}$ $\gamma = 103.103(7)^\circ$
 $V = 1099.13(15) \text{Å}^3$
 $Z=1, R1 = 4.39\%$
Triclinic system, P-1

Ref *Synth. Met.* 1991, 42, 1939-1942

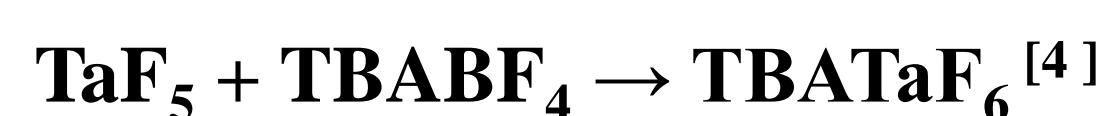
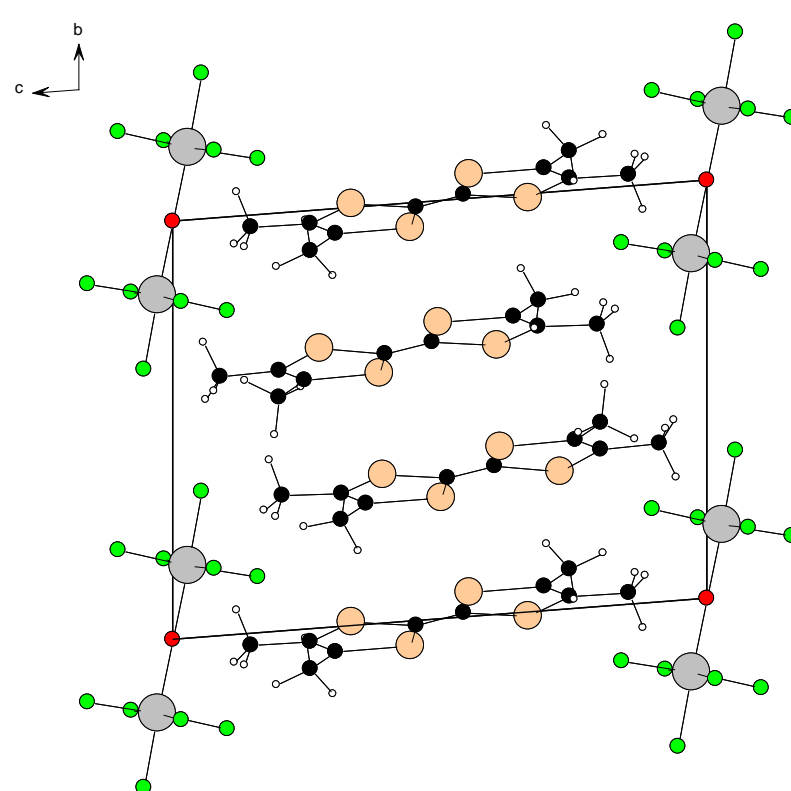
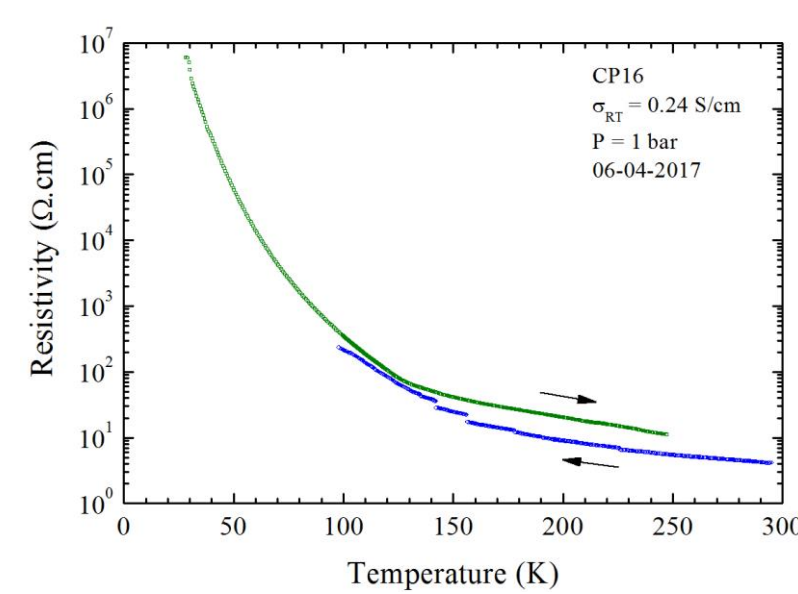

Unit cell, $T = 100 \text{ K}$, $\lambda = 1.54184 \text{ Å}$
 $a = 7.1344(4)\text{Å}$ $\alpha = 83.378(5)^\circ$
 $b = 7.7255(5)\text{Å}$ $\beta = 87.118(5)^\circ$
 $c = 13.7204(9)\text{Å}$ $\gamma = 70.200(6)^\circ$
 $V = 706.72(8) \text{Å}^3$
 $Z=1, R1 = 3.17\%$
Triclinic system, P-1

« Bechgaard » phase [3]

Ta^V-F bond lengths (Å)
Ta1-F(1) 1.892(3)
Ta1-F(2) 1.892(3)
Ta1-F(3) 1.895(3)

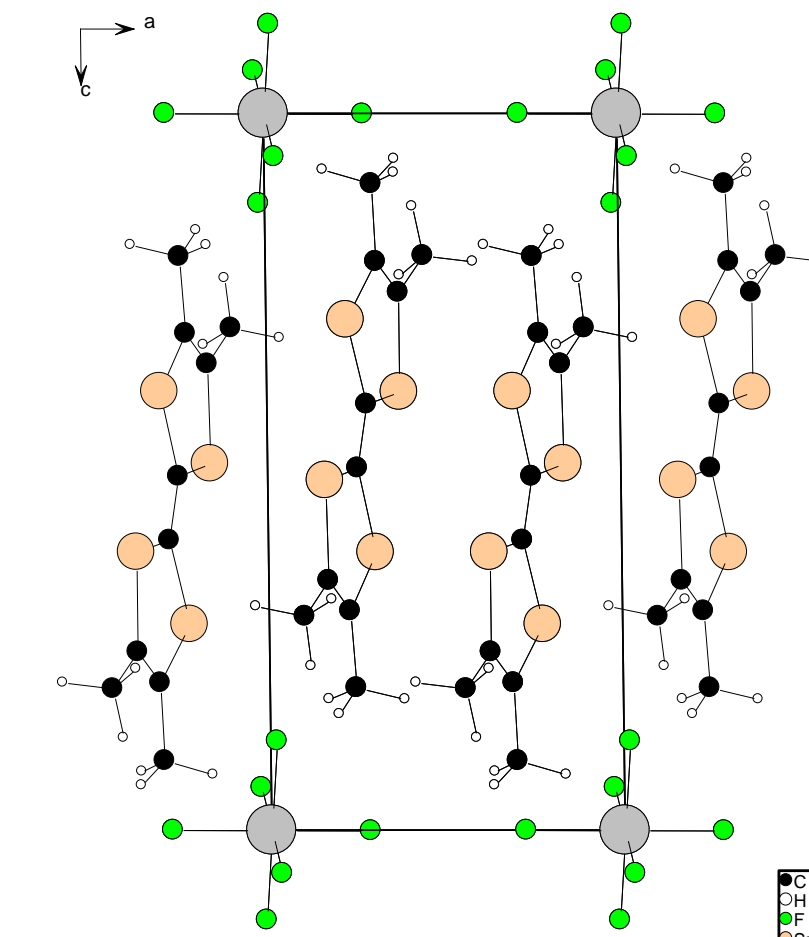
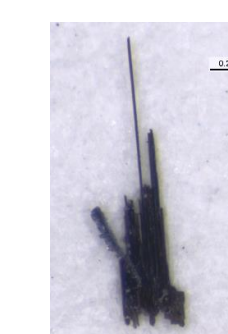

Focus : pre oxydation of the Re^{IV} salt in situ

\rightarrow New $(\text{TMTSeF})_2\text{ReO}_4$ phase = « Bechgaard » phase polymorph

$(\text{Ph}_3\text{-PNP-Ph}_3)_2 \text{Re}^{\text{IV}}\text{F}_6(\text{H}_2\text{O})_x$ salt: 2 éq. mol
Solvent : $\text{CH}_3\text{CN}/1.1.2 \text{ TCE } 11/1$
 $T = 20^\circ \text{ C}, I = 10 \mu\text{A}$ during 5 days in order to oxydize 50% of the anion
Then the TMTSeF is added in the anodic compartment and $I = 2 \mu\text{A}$

Shiny platelets : too small for physics!



Like $(\text{TMTSeF})_2\text{ClO}_4$ called « μ » phase [5]

Unit cell, $T = 150 \text{ K}$, $\lambda = 1.54184 \text{ Å}$
 $a = 11.7777(3)\text{Å}$
 $b = 8.7928(2)\text{Å}$ $\beta = 95.461(2)^\circ$
 $c = 27.0167(6)\text{Å}$
 $V = 2785.12(11) \text{Å}^3$
 $Z=4, R1 = 2.52\%$
Monoclinic system, C 2/c

