



HAL
open science

Modeling manufacturing systems in a dioid framework

Laurent Hardouin, Thomas Brunsch, Jörg Raisch

► **To cite this version:**

Laurent Hardouin, Thomas Brunsch, Jörg Raisch. Modeling manufacturing systems in a dioid framework. Javier Campos, Carla Seatzu, Xiaolan Xie. Formal Methods in Manufacturing, CRC Press, 2017, 9781138074293. hal-02535458

HAL Id: hal-02535458

<https://univ-angers.hal.science/hal-02535458>

Submitted on 7 Apr 2020

HAL is a multi-disciplinary open access archive for the deposit and dissemination of scientific research documents, whether they are published or not. The documents may come from teaching and research institutions in France or abroad, or from public or private research centers.

L'archive ouverte pluridisciplinaire **HAL**, est destinée au dépôt et à la diffusion de documents scientifiques de niveau recherche, publiés ou non, émanant des établissements d'enseignement et de recherche français ou étrangers, des laboratoires publics ou privés.

Chapter 1

Modeling manufacturing systems in a dioid framework

Thomas Brunsch, Laurent Hardouin, and Jörg Raisch

Abstract Many manufacturing systems are subject to synchronization phenomena but do not include choice. This class of manufacturing systems can be described as timed event graphs, which have a linear representation in an algebraic structure called dioids. Among the best known dioids is the max-plus algebra; there are, however, other dioids which, depending on the specific manufacturing system to be modeled, may be preferable. This chapter introduces basic notions of dioid theory and provides simple illustrative examples. Furthermore, the notion of standard dioids is extended such that minimal and maximal operation times as well as minimal and maximal numbers of parts being processed simultaneously can be modeled. Using this extension it is possible to model manufacturing systems with nested schedules, i.e., manufacturing processes in which parts may visit the same resource more than once and in which some activities related to part k may be executed prior to activities related to part $k - 1$ on the same resource. The resulting model of manufacturing systems may then be used to synthesize various forms of feedback control.

Thomas Brunsch and Jörg Raisch
Technische Universität Berlin, Fachgebiet Regelungssysteme, Einsteinufer 17, 10587 Berlin, Germany,
e-mail: {brunsch, raisch}@control.tu-berlin.de

Laurent Hardouin and Thomas Brunsch
Laboratoire d'Ingénierie des Systèmes Automatisés, Université d'Angers, 62 Avenue Notre-Dame du Lac, 49000 Angers, France.
e-mail: {laurent.hardouin@istia.univ-angers.fr}

Jörg Raisch
Fachgruppe System- und Regelungstheorie, Max-Planck-Institut für Dynamik komplexer technischer Systeme, Sandtorstr. 1, 39106 Magdeburg, Germany

1.1 Motivational Example

A small manufacturing process is considered, where two (different) parts A and B are pre-processed on two individual resources R_A and R_B . Once the pre-processing is done, a third resource R_C assembles both parts to a final part C . Thus, resource R_C has to wait for resource R_A and R_B to finish their processing, i.e., the release of part A and the release of part B have to be synchronized. In this process there are no (logical) decisions to make, as resource R_A can only process part A , resource R_B can only process part B and the assembly of both parts can only be conducted by resource R_C . Every process performed by the resources has a fixed processing time t_{p_i} , in which one part i is produced. Furthermore, every resource has a specific capacity cap_{R_i} , i.e., the number of parts that resource R_i can process simultaneously. Last but not least there are fixed transportation times for the provision of raw material for parts A and B , i.e., t_{raw_A} and t_{raw_B} , for the transfer of finished parts A and B to resource R_C , i.e., t_A and t_B , and for the transfer of part C (t_C) to some kind of storage for distribution or for further processing. The corresponding basic structure of our small manufacturing system is given in Fig. 1.1.

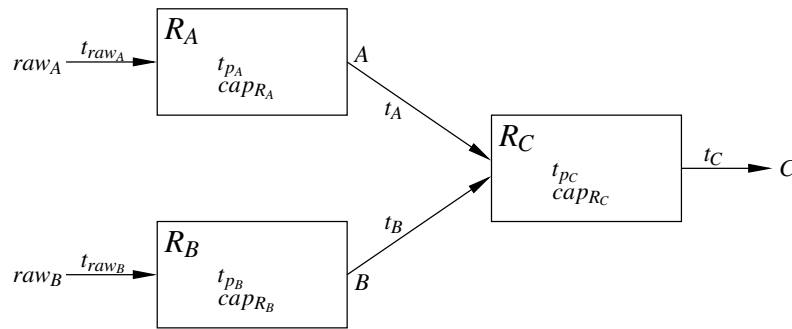

Fig. 1.1 Basic structure of a small manufacturing system considered in Chapter 1.

An important class of manufacturing systems can be modeled as Petri nets (for details see Chapter ?? of this book or [26]). This is obviously also true for our example system. In this chapter we focus on manufacturing systems that can be modeled as timed event graphs, a sub-class of Petri nets. In the following, the basics of this type of Petri nets is recalled. To do so we will adopt the notation for Petri nets introduced in Chapter ??.

1.2 Timed event graphs

A Petri net is called an event graph, if all arcs have the weight 1 and each place has exactly one input and one output transition, i.e., $|\bullet p_i| = |p_i \bullet| = 1$, $\forall p_i \in P$, with P being the (finite) set of places, and $|\bullet p_i|$ and $|p_i \bullet|$ being the number of input, respectively output, transitions of place p_i . In general, (standard) Petri nets, and consequently also event graphs, solely model the logical behavior of discrete-event systems, i.e., the possible sequences of firings of transitions, but not the actual firing times. As event graphs are a specific type of Petri nets, this is of course also true for event graphs. However, in many applications and especially in manufacturing systems, the specific firing times, or the earliest possible firing times of transitions are of particular interest. Therefore, standard (logical) event graphs have been equipped with timing information. Time can either be associated with transitions (representing transition delays) or with places (representing holding times). Equipping an event graph with either transition delays or holding times provides a timed event graph (TEG). In timed event graphs transition delays can always be converted into holding times (by simply shifting each transition delay to all input places of the corresponding transition). However, it is not possible to convert every TEG with holding times into a TEG with transition delays. Therefore, we will only consider timed event graphs with holding times.

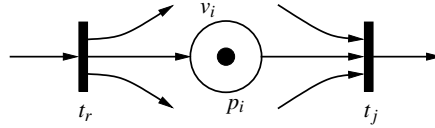

Fig. 1.2 Part of a timed event graph with holding times.

In a TEG with holding times, a token entering a place p_i has to spend v_i time units before it can contribute to the firing of its output transition. The graphical representation of a timed event graph with holding times is given in Fig. 1.2. The earliest time instant when p_i receives its k^{th} token is denoted $\pi_i(k)$, and the resulting earliest time instant that output transition t_j can fire for the k^{th} time is denoted $\tau_j(k)$ and can be determined by

$$\tau_j(k) = \max_{p_i \in \bullet t_j} (\pi_i(k) + v_i), \quad (1.1)$$

i.e., a transition can fire for the k^{th} time as soon as all its input places have received their k^{th} token and the corresponding holding times have elapsed. Similarly, the earliest time instants that a place p_i receives its $(k + m_i^0)^{\text{th}}$ token can be determined by the earliest firing instants of its input transition, i.e.,

$$\pi_i(k + m_i^0) = \tau_r(k), \quad t_r \in \bullet p_i. \quad (1.2)$$

Since every place in a TEG has exactly one input transition, it is possible to replace π_i in (1.1) with (1.2). Thus, recursive equations for the (earliest) firing times of transitions in TEG can be obtained.

Remark 1 (Earliest firing rule) *As mentioned before, a transition enabled to fire might not actually do so. As a matter of fact, it is not possible in TEG (or in Petri nets, in general) to force a transition to fire. In this work, however, we use the earliest firing rule, i.e., we assume that a transition fires as soon as it is enabled. This is a very weak assumption, since by definition there are no conflicting transitions in TEG.*

Example 1 (Manufacturing system) *Reconsidering the small manufacturing process introduced as a motivational example, we will show how this system can be modeled as a TEG. To do this, however, some additional information is necessary. First of all, the user has to decide which events are important or essential to model the system. For example, in some systems only the start and finish or release events are important, while in other systems further (internal) events have to be considered as well to represent the behavior of the manufacturing system.*

Assuming that the start and finish events are sufficient to model the behavior of the system we would obtain a TEG consisting of six transitions representing the three start and three finish events. The corresponding part of the TEG representing the processing of a single resource is given in Fig. 1.3. In this figure, t_i^s and t_i^e model

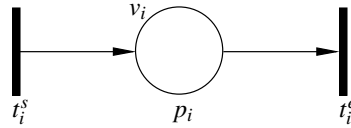

Fig. 1.3 Timed event graph representing the operation of a single resource.

the start and finish events of resource R_i and v_i is the (minimal) processing time for part i .

Additionally, the capacity of each resource needs to be included in the TEG model. This can be done by introducing an arc (with an additional place) from transition t_i^e to t_i^s . The number of tokens in this new place represents the capacity of the corresponding resource. Two tokens for example would mean, that t_i^s can fire twice more than t_i^e , which means that at most two parts can be processed at the same time. Note that this new place may also include a holding time, e.g., when a resource needs to cool down in between the processing of two parts. Finally, the user has to decide on the nature of different events. For example, there are input events, which are events that can be prevented from occurring. This is often the case for events representing the “feeding” of a resource with raw material or for start events of resources. Output events are usually the events that mark the finish of a final part or the finishing of an intermediate step. All other events are referred to

as internal events. Similar to standard systems theory input, internal, and output events are denoted u_i , x_i , and y_i , respectively.

Assume the following parameters for the manufacturing system given in Fig. 1.1

$$\begin{aligned} t_{raw_A} = t_{raw_B} = 0, \quad t_A = t_B = 1, \quad t_C = 0, \\ t_{p_A} = 10, \quad t_{p_B} = 4, \quad t_{p_C} = 3 \\ cap_{R_A} = 2, \quad cap_{R_B} = 1, \quad cap_{R_C} = 1 \end{aligned}$$

This means that raw material for R_A and R_B can be provided without time delay, the transfer of parts A and B to R_C takes 1 time unit, while the transfer of C to its destination is not delayed. The processing times for parts A, B, and C are 10, 4, and 3 time units, respectively, and while resource R_A has a capacity of 2 the other resources are of single capacity. The resulting timed event graph of this manufacturing system is given in Fig. 1.4. In this figure, x_1 and x_2 represent the start and

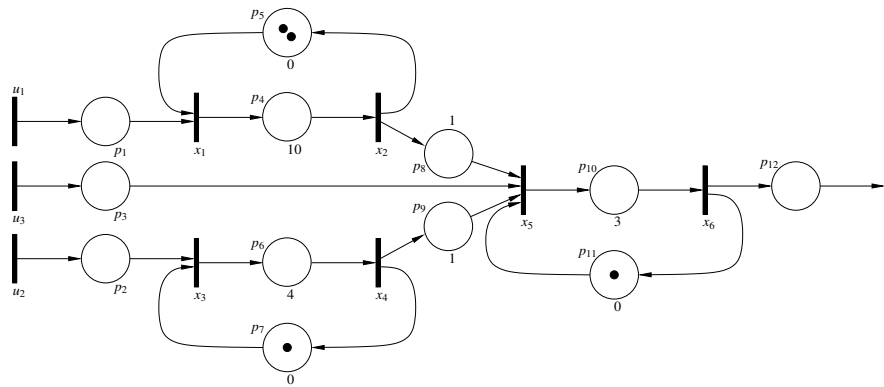

Fig. 1.4 Timed event graph of a simple manufacturing system.

finish events of resource R_A , x_3 and x_4 represent the start and finish events of R_B , and x_5 and x_6 the start and finish events of R_C .

Of particular interest is the dynamical evolution of the developed timed event graph, i.e., the firing instants of transitions. Let $x_i(k)$ denote the earliest possible time instant that transition x_i fires for the k^{th} time and $\pi_i(k)$ denotes the earliest time that place p_i receives its k^{th} token, then we get

$$x_1(k) = \max(\pi_1(k), \pi_5(k)) \quad (1.3)$$

$$x_2(k) = \pi_4(k) + 10 \quad (1.4)$$

$$x_3(k) = \max(\pi_2(k), \pi_7(k)) \quad (1.5)$$

$$x_4(k) = \pi_6(k) + 4 \quad (1.6)$$

$$x_5(k) = \max(\pi_3(k), \pi_8(k) + 1, \pi_9(k) + 1, \pi_{11}(k)) \quad (1.7)$$

$$x_6(k) = \pi_{10}(k) + 3. \quad (1.8)$$

With $u_i(k)$ denoting the earliest time instant of the k^{th} firing of u_i and taking the initial marking m^0 into account we get

$$\pi_1(k + m_1^0) = \pi_1(k) = u_1(k)$$

$$\pi_2(k + m_2^0) = \pi_2(k) = u_2(k)$$

$$\pi_3(k + m_3^0) = \pi_3(k) = u_3(k)$$

$$\pi_4(k + m_4^0) = \pi_4(k) = x_1(k)$$

$$\pi_5(k + m_5^0) = \pi_5(k + 2) = x_2(k)$$

$$\pi_6(k + m_6^0) = \pi_6(k) = x_3(k)$$

$$\pi_7(k + m_7^0) = \pi_7(k + 1) = x_4(k)$$

$$\pi_8(k + m_8^0) = \pi_8(k) = x_2(k)$$

$$\pi_9(k + m_9^0) = \pi_9(k) = x_4(k)$$

$$\pi_{10}(k + m_{10}^0) = \pi_{10}(k) = x_5(k)$$

$$\pi_{11}(k + m_{11}^0) = \pi_{11}(k + 1) = x_6(k)$$

$$\pi_{12}(k + m_{12}^0) = \pi_{12}(k) = x_6(k).$$

Then we can replace $\pi_i(k)$ in the equations (1.3)–(1.8) and obtain the recursive equations for the firing instants of transitions x_i

$$x_1(k) = \max(u_1(k), x_2(k - 2)) \quad (1.9)$$

$$x_2(k) = x_1(k) + 10 \quad (1.10)$$

$$x_3(k) = \max(u_2(k), x_4(k - 1)) \quad (1.11)$$

$$x_4(k) = x_3(k) + 4 \quad (1.12)$$

$$x_5(k) = \max(u_3(k), x_2(k) + 1, x_4(k) + 1, x_6(k - 1)) \quad (1.13)$$

$$x_6(k) = x_5(k) + 3. \quad (1.14)$$

In the same manner the earliest time instant of the firing of the output $y(k)$ can be determined

$$y(k) = x_6(k).$$

Given a firing vector $\mathbf{u}(k) = [u_1(k) u_2(k) u_3(k)]^T$ and using equations (1.9)–(1.14) the firing vector $\mathbf{x}(k) = [x_1(k) x_2(k) x_3(k) x_4(k) x_5(k) x_6(k)]^T$ can be determined for $k = 1, 2, \dots$. Assuming that the input shall not slow down the system, e.g., an unlimited number of raw parts are available at time 0, which is equivalent to $\mathbf{u}(k) = [000]^T \forall k \in \mathbb{N}$ and setting $x_i(k) = -\infty \forall k \leq 0$ the firing vector results in

$$\underbrace{\begin{bmatrix} 0 \\ 10 \\ 0 \\ 4 \\ 11 \\ 14 \end{bmatrix}}_{\mathbf{x}(1)}, \underbrace{\begin{bmatrix} 0 \\ 10 \\ 4 \\ 8 \\ 14 \\ 17 \end{bmatrix}}_{\mathbf{x}(2)}, \underbrace{\begin{bmatrix} 10 \\ 20 \\ 8 \\ 12 \\ 21 \\ 24 \end{bmatrix}}_{\mathbf{x}(3)}, \underbrace{\begin{bmatrix} 10 \\ 20 \\ 12 \\ 16 \\ 24 \\ 27 \end{bmatrix}}_{\mathbf{x}(4)}, \underbrace{\begin{bmatrix} 20 \\ 30 \\ 16 \\ 20 \\ 31 \\ 34 \end{bmatrix}}_{\mathbf{x}(5)}, \dots$$

Clearly, determining the firing instants using the recursive equations (1.9)–(1.14) may be quite cumbersome. Taking a closer look at these equations, one realizes that addition and the maximum operation are essential to determine the desired firing times. Due to the maximum operation, the equations are non-linear in conventional algebra, however, there is a mathematical structure called idempotent semirings (or dioids) in which the recurrence relation of the firing instants have a linear representation.

1.3 Mathematical Background

This section provides the algebraic background necessary to obtain a linear representation of the firing instants in a timed event graph. This section is rather technical and does not claim to be a complete presentation. For a more exhaustive description of the mathematical background, the interested reader is referred to [2].

1.3.1 Ordered sets

Before introducing the basic notion of idempotent semirings (or dioids), the fundamentals of ordered sets will be recalled.

Definition 1 (Order relation) A binary relation \preceq on a set \mathcal{C} is an order relation if the following properties hold $\forall a, b, c \in \mathcal{C}$

- reflexivity: $a \preceq a$
- anti-symmetry: $(a \preceq b \text{ and } b \preceq a) \Rightarrow a = b$
- transitivity: $(a \preceq b \text{ and } b \preceq c) \Rightarrow a \preceq c$

Definition 2 (Ordered set) A set \mathcal{C} endowed with an order relation \preceq is said to be an ordered set and is denoted (\mathcal{C}, \preceq) . It is said to be a totally ordered set if any pair

of elements in \mathcal{C} can be compared with respect to \preceq , i.e., $\forall a, b \in \mathcal{C}$ one can either write $a \preceq b$ or $b \preceq a$. Otherwise (\mathcal{C}, \preceq) is said to be partially ordered.

Example 2 (Ordered sets) A classical example of an ordered set is (\mathbb{Z}, \leq) , i.e., the set of (scalar) integers endowed with the classical “less or equal” order relation. Clearly, (\mathbb{Z}, \leq) is totally ordered. The ordered set (\mathbb{Z}^2, \leq) , however, is only partially ordered as it is not possible to compare any pair of vectors with integer entries. Note that for two vectors \mathbf{x} and $\mathbf{y} \in \mathbb{Z}^2$, $\mathbf{x} = [x_1 x_2]^T \leq \mathbf{y} = [y_1 y_2]^T$ if $x_1 \leq y_1$ and $x_2 \leq y_2$. For example, the vectors $[a, b]^T$ and $[b, a]^T$ are not related when $a \neq b$.

Definition 3 (Bounds on ordered sets) Given a non-empty subset $\mathcal{S} \subseteq \mathcal{C}$ of an ordered set (\mathcal{C}, \preceq) , element $a \in \mathcal{C}$ is called lower bound of \mathcal{S} if $\forall b \in \mathcal{S} : a \preceq b$. If \mathcal{S} has a lower bound, its greatest lower bound (glb) is denoted $\bigwedge \mathcal{S}$. Similarly, an element $c \in \mathcal{C}$ is called upper bound of \mathcal{S} if $\forall b \in \mathcal{S} : b \preceq c$. If \mathcal{S} has an upper bound, its least upper bound (lub) is denoted $\bigvee \mathcal{S}$.

Definition 4 (Lattices) An ordered set (\mathcal{C}, \preceq) is called sup-semi-lattice, if $\forall a, b \in \mathcal{C}$ there exists $a \vee b$. It is a complete sup-semi-lattice, if for every subset $\mathcal{S} \subseteq \mathcal{C}$ there exists a least upper bound, i.e., $\bigvee \mathcal{S}$ exists $\forall \mathcal{S} \subseteq \mathcal{C}$. Analogously, an ordered set (\mathcal{C}, \preceq) is called an inf-semi-lattice, if $\forall a, b \in \mathcal{C}$ there exists $a \wedge b$, and it is called complete inf-semi-lattice, if $\forall \mathcal{S} \subseteq \mathcal{C}$, there exists a least upper bound $\bigwedge \mathcal{S}$. If an ordered set (\mathcal{C}, \preceq) forms a sup-semi-lattice as well as a inf-semi-lattice, it is called a lattice and denoted $(\mathcal{C}, \vee, \wedge)$. In lattices the following properties hold $\forall a, b \in \mathcal{C}$:

$$a \preceq b \Leftrightarrow a \vee b = b \Leftrightarrow a \wedge b = a.$$

A lattice is called a complete (or bounded) lattice if it is a complete sup-semi-lattice as well as a complete inf-semi-lattice. The upper and lower bound of a complete lattice are denoted \top (top element) and \perp (bottom element), respectively.

Remark 2 The operations \vee and \wedge of a lattice $(\mathcal{C}, \vee, \wedge)$ are associative, commutative, idempotent, and the absorption property, i.e., $a \vee (a \wedge b) = a$ and $a \wedge (a \vee b) = a$, $\forall a, b \in \mathcal{C}$, holds.

Definition 5 (Isotone mapping) A mapping $f : \mathcal{C} \rightarrow \mathcal{D}$ from an ordered set (\mathcal{C}, \preceq) to an ordered set (\mathcal{D}, \preceq) is order-preserving or isotone if $\forall a, b \in \mathcal{C}$

$$a \preceq b \Rightarrow f(a) \preceq f(b).$$

Definition 6 (Semi-continuous mapping) A mapping $f : \mathcal{C} \rightarrow \mathcal{D}$ from a complete lattice $(\mathcal{C}, \vee, \wedge)$ to a complete lattice $(\mathcal{D}, \vee, \wedge)$ is lower semi-continuous (l.s.c.) if for any subset $\mathcal{S} \subseteq \mathcal{C}$

$$f\left(\bigvee_{a \in \mathcal{S}} a\right) = \bigvee_{a \in \mathcal{S}} f(a).$$

Analogously, $f : \mathcal{C} \rightarrow \mathcal{D}$ is called upper semi-continuous (u.s.c.) if

$$f\left(\bigwedge_{a \in \mathcal{S}} a\right) = \bigwedge_{a \in \mathcal{S}} f(a), \quad \forall \mathcal{S} \subseteq \mathcal{C}.$$

Definition 7 (Continuous mapping) A mapping $f : \mathcal{C} \rightarrow \mathcal{D}$ is said to be continuous if it is lower semi-continuous as well as upper semi-continuous.

Remark 3 Given two complete lattices $(\mathcal{C}, \vee, \wedge)$ and $(\mathcal{D}, \vee, \wedge)$, it can easily be shown that a l.s.c. mapping $f : \mathcal{C} \rightarrow \mathcal{D}$ is isotone by considering arbitrary $a, b \in \mathcal{C}$. If $a \preceq b$, then $a \vee b = b$ and since f is l.s.c., $f(a \vee b) = f(a) \vee f(b) = f(b)$ and therefore $f(a) \preceq f(b)$. Additionally, it can be shown that an u.s.c. mapping $f : \mathcal{C} \rightarrow \mathcal{D}$ is also isotone. Considering two arbitrary elements $a, b \in \mathcal{C}$ with $a \preceq b$ one can write $a \wedge b = a$ and since f is u.s.c., it is clear that $f(a \wedge b) = f(a) \wedge f(b) = f(a)$ and, consequently, $f(a) \preceq f(b)$.

1.3.2 Idempotent semirings

Definition 8 (Monoid) A monoid, (\mathcal{M}, \cdot, e) , is a set \mathcal{M} endowed with an internal binary operation \cdot , which is associative, and with an identity element e . If the internal law \cdot is commutative, (\mathcal{M}, \cdot, e) is said to be a commutative monoid. If the internal law \cdot is idempotent, i.e., $a \cdot a = a \forall a \in \mathcal{M}$, the monoid is said to be idempotent.

Definition 9 (Dioid) An idempotent semiring (also called dioid) is a set \mathcal{D} , endowed with two internal operations denoted \oplus (addition) and \otimes (multiplication) such that $(\mathcal{D}, \oplus, \varepsilon)$ constitutes an idempotent commutative monoid and $(\mathcal{D}, \otimes, e)$ constitutes a monoid. Furthermore, multiplication is left- and right-distributive with respect to addition, i.e., $a \otimes (b \oplus c) = (a \otimes b) \oplus (a \otimes c)$ and $(a \oplus b) \otimes c = (a \otimes c) \oplus (b \otimes c) \forall a, b, c \in \mathcal{D}$, and ε is absorbing with respect to multiplication, i.e., $a \otimes \varepsilon = \varepsilon \otimes a = \varepsilon \forall a \in \mathcal{D}$. The dioid is denoted $(\mathcal{D}, \oplus, \otimes)$ and the neutral elements of addition and multiplication are referred to as zero and unit element, respectively. If multiplication is commutative, the corresponding dioid is said to be commutative. If all elements of the dioid (except ε) have a multiplicative inverse, the idempotent semiring forms an idempotent semifield.

Consequently, the internal laws of an idempotent semiring have the following properties $\forall a, b, c \in \mathcal{D}$

- addition:
 - associativity: $(a \oplus b) \oplus c = a \oplus (b \oplus c)$
 - commutativity: $a \oplus b = b \oplus a$
 - idempotency: $a \oplus a = a$
 - neutral element: $a \oplus \varepsilon = a$
- multiplication:

- associativity: $(a \otimes b) \otimes c = a \otimes (b \otimes c)$
- neutral element: $a \otimes e = e \otimes a = a$

Remark 4 *As in classical algebra, the multiplication sign \otimes is often omitted when unambiguous.*

Example 3 (Max-plus algebra) *Probably the most widely know idempotent semiring is the so-called max-plus algebra. It is defined on the set $\mathbb{Z}_{\max} = \mathbb{Z} \cup \{-\infty\}$. Max-plus addition is defined as the classical maximum operation and max-plus multiplication is the classical addition, i.e., $a \oplus b := \max(a, b)$ and $a \otimes b := a + b$, $\forall a, b \in \mathbb{Z}_{\max}$. The zero and unit elements of max-plus algebra are $\varepsilon = -\infty$ and $e = 0$, respectively. Note that max-plus algebra may also be defined on the set $\mathbb{R}_{\max} = \mathbb{R} \cup \{-\infty\}$.*

Example 4 (Min-plus algebra) *Another popular idempotent semiring is the min-plus algebra. It is defined on the set $\mathbb{Z}_{\min} = \mathbb{Z} \cup \{+\infty\}$ (or $\mathbb{R}_{\min} = \mathbb{R} \cup \{+\infty\}$), and its operations are defined as: $a \oplus b = \min(a, b)$ and $a \otimes b = a + b$, $\forall a, b \in \mathbb{Z}_{\min}$ (resp. \mathbb{R}_{\min}). The corresponding zero and unit elements are $\varepsilon = +\infty$ and $e = 0$, respectively.*

Definition 10 (Sub-semiring) *Given an idempotent semiring $(\mathcal{D}, \oplus, \otimes)$, the algebraic structure $(\mathcal{S}, \oplus, \otimes)$ is called sub-semiring of $(\mathcal{D}, \oplus, \otimes)$, if*

- \mathcal{S} is a subset of \mathcal{D} , i.e., $\mathcal{S} \subseteq \mathcal{D}$;
- the zero and unit elements of $(\mathcal{D}, \oplus, \otimes)$ are included in \mathcal{S} , i.e., $\varepsilon \in \mathcal{S}$ and $e \in \mathcal{S}$;
- \mathcal{S} is closed for addition and multiplication, i.e., $a \oplus b \in \mathcal{S}$ and $a \otimes b \in \mathcal{S}$, $\forall a, b \in \mathcal{S}$.

Example 5 *According to the definition of a sub-semiring, it is clear that $(\mathbb{Z}_{\max}, \oplus, \otimes)$ is a sub-semiring of $(\mathbb{R}_{\max}, \oplus, \otimes)$.*

Remark 5 (Dioid of matrices) *Just as in the classical algebra, the notion of dioids can easily be extended to the matrix case. Addition and multiplication for the matrices $\mathbf{A}, \mathbf{B} \in \mathcal{D}^{n \times p}$ and $\mathbf{C} \in \mathcal{D}^{p \times m}$ are defined by*

$$\begin{aligned} [\mathbf{A} \oplus \mathbf{B}]_{ij} &= [\mathbf{A}]_{ij} \oplus [\mathbf{B}]_{ij} & \forall i = 1, \dots, n; \forall j = 1, \dots, p; \\ [\mathbf{A} \otimes \mathbf{C}]_{ij} &= \bigoplus_{k=1}^p [\mathbf{A}]_{ik} \otimes [\mathbf{C}]_{kj} & \forall i = 1, \dots, n; \forall j = 1, \dots, m. \end{aligned}$$

Example 6 (Matrix operations in max-plus algebra) *Given three matrices with entries in \mathbb{Z}_{\max} ,*

$$\mathbf{A} = \begin{bmatrix} 1 & 4 \\ 5 & 3 \\ \varepsilon & 2 \end{bmatrix}, \quad \mathbf{B} = \begin{bmatrix} 3 & 3 \\ 2 & 4 \\ 7 & 1 \end{bmatrix}, \quad \text{and} \quad \mathbf{C} = \begin{bmatrix} e & 4 \\ 1 & 3 \end{bmatrix},$$

we get

$$\mathbf{A} \oplus \mathbf{B} = \begin{bmatrix} 1 & 4 \\ 5 & 3 \\ \varepsilon & 2 \end{bmatrix} \oplus \begin{bmatrix} 3 & 3 \\ 2 & 4 \\ 7 & 1 \end{bmatrix} = \begin{bmatrix} 3 & 4 \\ 5 & 4 \\ 7 & 2 \end{bmatrix}$$

$$\mathbf{A} \otimes \mathbf{C} = \begin{bmatrix} 1 & 4 \\ 5 & 3 \\ \varepsilon & 2 \end{bmatrix} \otimes \begin{bmatrix} e & 4 \\ 1 & 3 \end{bmatrix} = \begin{bmatrix} 5 & 7 \\ 5 & 9 \\ 3 & 5 \end{bmatrix}.$$

1.3.3 Natural order in idempotent semirings

Due to the idempotency property of addition in dioids, they can be naturally equipped with an order:

$$a \oplus b = b \Leftrightarrow a \preceq b.$$

It can be easily checked that \preceq is indeed reflexive, anti-symmetric, and transitive.

Remark 6 Note that the natural order in dioids may be partial or total. E.g., max-plus algebra defined on scalars is totally ordered, while matrices in max-plus algebra are only partially ordered (see Ex. 6).

Definition 11 (Complete dioids) An idempotent semiring $(\mathcal{D}, \oplus, \otimes)$ is said to be complete if it is closed for infinite sums and if multiplication distributes over infinite sums, i.e., $\forall a \in \mathcal{D}$ and $\forall \mathcal{S} \subseteq \mathcal{D}$

$$a \otimes \left(\bigoplus_{b \in \mathcal{S}} b \right) = \bigoplus_{b \in \mathcal{S}} a \otimes b \quad \text{and} \quad \left(\bigoplus_{b \in \mathcal{S}} b \right) \otimes a = \bigoplus_{b \in \mathcal{S}} b \otimes a.$$

Consequently, a complete dioid $(\mathcal{D}, \oplus, \otimes)$ admits a greatest element, the so-called top element, which corresponds to the sum of all elements in \mathcal{D} , i.e., $\top = \bigoplus_{a \in \mathcal{D}} a$ and $\top \in \mathcal{D}$.

Remark 7 With respect to lattice theory, a dioid $(\mathcal{D}, \oplus, \otimes)$ constitutes an ordered set (\mathcal{D}, \preceq) with the structure of a sup-semi-lattice and with $a \oplus b$ being the least upper bound of a and b . A complete dioid has the structure of a complete sup-semi-lattice with $\top = \bigvee \mathcal{D} = \bigoplus_{a \in \mathcal{D}} a$. Moreover, since every dioid admits $\varepsilon \in \mathcal{D}$ as a greatest lower bound, i.e., $\varepsilon = \bigwedge \mathcal{D}$, a complete dioid has the structure of a complete lattice $(\mathcal{D}, \oplus, \wedge)$ with $a \oplus b = b \Leftrightarrow a \preceq b \Leftrightarrow a \wedge b = a$.

Example 7 (Max-plus algebra) The natural order in max-plus algebra $(\mathbb{Z}_{\max}, \oplus, \otimes)$ coincides with the order relation in classical algebra, e.g., $1 \preceq 3$ since $1 \oplus 3 = 3$. $(\mathbb{Z}_{\max}, \oplus, \otimes)$ does not constitute a complete dioid since $\bigoplus_{a \in \mathbb{Z}_{\max}} a = \top \notin \mathbb{Z}_{\max}$. If, however, max-plus algebra is defined on $\overline{\mathbb{Z}}_{\max} = \mathbb{Z}_{\max} \cup \{+\infty\} = \mathbb{Z} \cup \{-\infty, +\infty\}$, it becomes a complete dioid and, consequently, $(\overline{\mathbb{Z}}_{\max}, \oplus, \wedge)$ is a complete lattice.

Example 8 (Min-plus algebra) The natural order in min-plus algebra corresponds to the “reverse” of the order relation in classical algebra, e.g., $3 \preceq 1$ since $1 \oplus 3 = 1$.

Similar to max-plus algebra, min-plus algebra constitutes a complete dioid if it is defined on $\overline{\mathbb{Z}}_{\min} = \mathbb{Z}_{\min} \cup \{-\infty\} = \mathbb{Z} \cup \{-\infty, +\infty\}$ (with $\top = -\infty$) and, thus, $(\overline{\mathbb{Z}}_{\min}, \oplus, \wedge)$ has the structure of a complete lattice.

1.3.4 Mappings in idempotent semirings

Recall that a (complete) dioid is a (complete) lattice, with \oplus playing the role of \vee . Therefore, a mapping f from a complete dioid $(\mathcal{D}, \oplus, \otimes)$ to a complete dioid $(\mathcal{C}, \oplus, \otimes)$ is lower semi-continuous if $\forall \mathcal{S} \subseteq \mathcal{D}$

$$f\left(\bigoplus_{a \in \mathcal{S}} a\right) = \bigoplus_{a \in \mathcal{S}} f(a),$$

and upper semi-continuous if $\forall \mathcal{S} \subseteq \mathcal{D}$

$$f\left(\bigwedge_{a \in \mathcal{S}} a\right) = \bigwedge_{a \in \mathcal{S}} f(a).$$

Definition 12 (Homomorphism) A mapping $f : \mathcal{D} \rightarrow \mathcal{C}$ is a homomorphism if $\forall a, b \in \mathcal{D}$

$$\begin{aligned} f(a \oplus b) &= f(a) \oplus f(b) & \text{and} & & f(\varepsilon) &= \varepsilon \\ f(a \otimes b) &= f(a) \otimes f(b) & \text{and} & & f(e) &= e. \end{aligned}$$

Definition 13 (Isomorphism) If the inverse of a homomorphism f is defined and is itself a homomorphism the mapping f is called an isomorphism.

Definition 14 (Image of a mapping) The image of a mapping $f : \mathcal{D} \rightarrow \mathcal{C}$ is

$$\text{Im}f = \{b \in \mathcal{C} \mid b = f(a), a \in \mathcal{D}\}.$$

Definition 15 (Identity mapping) A mapping $f : \mathcal{D} \rightarrow \mathcal{D}$ is called identity mapping and denoted $\text{Id}_{\mathcal{D}}$, if $f(a) = a, \forall a \in \mathcal{D}$.

Definition 16 (Closure mapping) A mapping $f : \mathcal{D} \rightarrow \mathcal{D}$, is called closure mapping, if it is

- extensive, i.e., $f(a) \succeq a$
- idempotent, i.e., $f \circ f = f$
- isotone, i.e., $a \preceq b \Rightarrow f(a) \preceq f(b), \forall a, b \in \mathcal{D}$.

Remark 8 For closure mappings, the following holds

$$x = f(x) \Leftrightarrow x \in \text{Im}f.$$

1.3.5 Residuation theory

Multiplication in idempotent semirings does not necessarily admit an inverse. However, a pseudo inversion of mappings defined over ordered sets is provided by the so-called residuation theory [3, 4]. Since dioids are defined on (partially) ordered sets, it is possible to use residuation theory to determine the greatest solution (with respect to the natural order of the dioid) of inequality $f(a) \preceq b$. Let $(\mathcal{D}, \oplus, \otimes)$ and $(\mathcal{C}, \oplus, \otimes)$ be dioids, then:

Definition 17 (Residuated mapping) An isotone mapping $f : \mathcal{D} \rightarrow \mathcal{C}$ is said to be residuated, if the inequality $f(a) \preceq b$ has a greatest solution in \mathcal{D} for all $b \in \mathcal{C}$.

Theorem 1 ([4]) An isotone mapping $f : \mathcal{D} \rightarrow \mathcal{C}$ is residuated if and only if there exists a unique isotone mapping $f^\sharp : \mathcal{C} \rightarrow \mathcal{D}$ such that $(f \circ f^\sharp)(b) \preceq b, \forall b \in \mathcal{C}$ and $(f^\sharp \circ f)(a) \succeq a, \forall a \in \mathcal{D}$. Mapping f^\sharp is called the residual of f .

Theorem 2 ([2]) For a residuated mapping $f : \mathcal{D} \rightarrow \mathcal{C}$, the following equalities hold:

$$\begin{aligned} f \circ f^\sharp \circ f &= f \\ f^\sharp \circ f \circ f^\sharp &= f^\sharp \end{aligned}$$

An illustration of these properties is given in Fig. 1.5.

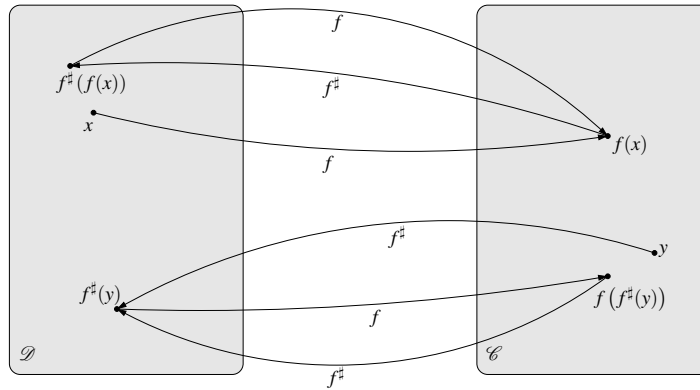

Fig. 1.5 Properties of residuated mapping $f : \mathcal{D} \rightarrow \mathcal{C}$ and the corresponding mapping $f^\sharp : \mathcal{C} \rightarrow \mathcal{D}$.

It can be shown that two very elementary mappings in a complete dioid $(\mathcal{D}, \oplus, \otimes)$, namely, the left and right multiplication by a constant, i.e.,

$$\begin{aligned}
L_a : \mathcal{D} &\rightarrow \mathcal{D} \\
x &\mapsto a \otimes x \\
R_a : \mathcal{D} &\rightarrow \mathcal{D} \\
x &\mapsto x \otimes a
\end{aligned}$$

are residuated mappings. The corresponding residual mappings are denoted:

$$\begin{aligned}
L_a^\sharp(x) &= a \wp x \\
R_a^\sharp(x) &= x \wp a.
\end{aligned}$$

Consequently, $a \otimes x \preceq b$ has the greatest solution $L_a^\sharp(b) = a \wp b = \bigoplus_{x \in \mathcal{D}} \{x \mid ax \preceq b\}$. Analogously, the greatest solution of $x \otimes a \preceq b$ is $R_a^\sharp(b) = b \wp a = \bigoplus_{x \in \mathcal{D}} \{x \mid xa \preceq b\}$. Specifically, inequalities $\varepsilon \otimes x \preceq b$ and $x \otimes \varepsilon \preceq b$ have the greatest solution $\varepsilon \wp b = b \wp \varepsilon = \top$, and inequalities $\top \otimes x \preceq b$ and $x \otimes \top \preceq b$ admit the greatest solutions

$$\top \wp b = b \wp \top = \begin{cases} \top & \text{if } b = \top \\ \varepsilon & \text{else.} \end{cases}$$

Residuation theory can also be used to find the greatest solutions of matrix inequalities, where the order relation \preceq is interpreted element-wise. Given matrices $\mathbf{A}, \mathbf{D} \in \mathcal{D}^{m \times n}$, $\mathbf{B} \in \mathcal{D}^{m \times p}$, and $\mathbf{C} \in \mathcal{D}^{n \times p}$, the greatest solution of inequality $\mathbf{A} \otimes \mathbf{X} \preceq \mathbf{B}$ is given by $\mathbf{C} = \mathbf{A} \wp \mathbf{B}$ and inequality $\mathbf{X} \otimes \mathbf{C} \preceq \mathbf{B}$ admits $\mathbf{D} = \mathbf{B} \wp \mathbf{C}$ as its greatest solution. The entries of \mathbf{C} and \mathbf{D} are determined as follows [6]:

$$\begin{aligned}
[\mathbf{C}]_{ij} &= \bigwedge_{k=1}^m ([\mathbf{A}]_{ki} \wp [\mathbf{B}]_{kj}) \\
[\mathbf{D}]_{ij} &= \bigwedge_{k=1}^p ([\mathbf{B}]_{ik} \wp [\mathbf{C}]_{jk}).
\end{aligned}$$

Example 9 (Max-plus algebra) *Considering the relation $\mathbf{A} \otimes \mathbf{X} \preceq \mathbf{B}$ with*

$$\mathbf{A} = \begin{bmatrix} 1 & 2 \\ 3 & 4 \\ 5 & \varepsilon \end{bmatrix} \quad \text{and} \quad \mathbf{B} = \begin{bmatrix} 6 \\ 7 \\ 8 \end{bmatrix}$$

being matrices with entries in $\overline{\mathbb{Z}}_{\max}$. As the max-plus multiplication corresponds to the classical addition, its residual corresponds to the classical subtraction, i.e., $1 \otimes x \preceq 4$ admits the solution set $\mathcal{X} = \{x \mid x \preceq 1 \wp 4\}$ with $1 \wp 4 = 4 - 1 = 3$ being the greatest solution of this set. Applying the rules of residuation in max-plus algebra to the relation $\mathbf{A} \otimes \mathbf{X} \preceq \mathbf{B}$ results in:

$$\mathbf{A} \wp \mathbf{B} = \begin{bmatrix} 1 \wp 6 \wedge 3 \wp 7 \wedge 5 \wp 8 \\ 2 \wp 6 \wedge 4 \wp 7 \wedge \varepsilon \wp 8 \end{bmatrix} = \begin{bmatrix} 3 \\ 3 \end{bmatrix}.$$

Matrix $A \dot{\phi} B = [3 \ 3]^T$ is the greatest solution for X which ensures $A \otimes X \preceq B$. Indeed,

$$A \otimes (A \dot{\phi} B) = \begin{bmatrix} 1 & 2 \\ 3 & 4 \\ 5 & \varepsilon \end{bmatrix} \otimes \begin{bmatrix} 3 \\ 3 \end{bmatrix} = \begin{bmatrix} 5 \\ 7 \\ 8 \end{bmatrix} \preceq \begin{bmatrix} 6 \\ 7 \\ 8 \end{bmatrix} = B.$$

Remark 9 Note that residuation achieves equality in the case of scalar multiplication in max-plus algebra, while this is not true for the matrix case.

Below, some properties of the residuals $L_a^\#$ and $R_a^\#$ are given. To get a more exhaustive list of properties and the corresponding proofs the reader is invited to consult [2, 8, 13].

$$a (a \dot{\phi} x) \preceq x \qquad (x \phi a) a \preceq x \qquad (1.15)$$

$$a \dot{\phi} (ax) \succeq x \qquad (xa) \phi a \succeq x \qquad (1.16)$$

$$a (a \dot{\phi} (ax)) = ax \qquad ((xa) \phi a) a = xa \qquad (1.17)$$

$$a \dot{\phi} (a (a \dot{\phi} x)) = a \dot{\phi} x \qquad ((x \phi a) a) \phi a = x \phi a \qquad (1.18)$$

$$a \dot{\phi} (x \wedge y) = a \dot{\phi} x \wedge a \dot{\phi} y \qquad (x \wedge y) \phi a = x \phi a \wedge y \phi a \qquad (1.19)$$

$$a \dot{\phi} (x \oplus y) \succeq (a \dot{\phi} x) \oplus (a \dot{\phi} y) \qquad (x \oplus y) \phi a \succeq (x \phi a) \oplus (y \phi a) \qquad (1.20)$$

$$(a \wedge b) \dot{\phi} x \succeq (a \dot{\phi} x) \oplus (b \dot{\phi} x) \qquad x \phi (a \wedge b) \succeq (x \phi a) \oplus (x \phi b) \qquad (1.21)$$

$$(a \oplus b) \dot{\phi} x = a \dot{\phi} x \wedge b \dot{\phi} x \qquad x \phi (a \oplus b) = x \phi a \wedge x \phi b \qquad (1.22)$$

$$(ab) \dot{\phi} x = b \dot{\phi} (a \dot{\phi} x) \qquad x \phi (ba) = (x \phi a) \phi b \qquad (1.23)$$

$$(a \dot{\phi} x) b \preceq a \dot{\phi} (xb) \qquad b (x \phi a) \preceq (bx) \phi a \qquad (1.24)$$

$$b (a \dot{\phi} x) \preceq (a \phi b) \dot{\phi} x \qquad (x \phi a) b \preceq x \phi (b \dot{\phi} a) \qquad (1.25)$$

Definition 18 (Canonical injection) An isotone mapping $f : \mathcal{S} \rightarrow \mathcal{D}$ with \mathcal{S} a sub-semiring of the dioid \mathcal{D} and both \mathcal{S} and \mathcal{D} being complete, is called canonical injection if

$$f(a) = a \quad \forall a \in \mathcal{S}.$$

Theorem 3 (Projection [13]) According to the definition of a residuated mapping (Def. 17), the canonical injection $f_{\mathcal{S}}$ is a residuated mapping. The residual $f_{\mathcal{S}}^\#$ is a projector from the dioid \mathcal{D} to its sub-dioid \mathcal{S} and denoted $\text{Pr}_{\mathcal{S}}$. The following statements hold for $\text{Pr}_{\mathcal{S}}$:

- (i) $\text{Pr}_{\mathcal{S}} \circ \text{Pr}_{\mathcal{S}} = \text{Pr}_{\mathcal{S}}$
- (ii) $\text{Pr}_{\mathcal{S}}(b) \preceq b \quad \forall b \in \mathcal{D}$
- (iii) $a \in \mathcal{S} \Leftrightarrow \text{Pr}_{\mathcal{S}}(a) = a$.

1.3.6 Fixed point equations

Theorem 4 (Fixpoint theorem [17, 29]) *Every order preserving mapping of a complete lattice (\mathcal{C}, \preceq) into itself has at least one fixpoint. The set of fixpoints of such a mapping forms a complete lattice with respect to the ordering of (\mathcal{C}, \preceq) . Formally, for an isotone mapping $f : \mathcal{C} \rightarrow \mathcal{C}$ with $(\mathcal{C}, \vee, \wedge)$ being a complete lattice and $\mathcal{Y} = \{x \in \mathcal{C} \mid f(x) = x\}$ being the set of fixed points of f , one can write*

1. $\bigwedge_{y \in \mathcal{Y}} y \in \mathcal{Y}$, and $\bigwedge_{y \in \mathcal{Y}} y = \bigwedge \{x \in \mathcal{C} \mid f(x) \preceq x\}$.
2. $\bigvee_{y \in \mathcal{Y}} y \in \mathcal{Y}$, and $\bigvee_{y \in \mathcal{Y}} y = \bigvee \{x \in \mathcal{C} \mid x \preceq f(x)\}$.

Theorem 5 (Smallest fixed point [2]) *Let $(\mathcal{D}, \oplus, \otimes)$ be a complete dioid, $f : \mathcal{D} \rightarrow \mathcal{D}$ be a lower semi-continuous mapping in this dioid, and \mathcal{Y} the set of fixed points of f . The smallest fixed point of f is*

$$\bigwedge_{y \in \mathcal{Y}} y = f^* \left(\bigwedge_{x \in \mathcal{D}} x \right) = f^*(\varepsilon)$$

$$\text{with } f^*(x) = \bigoplus_{i=0}^{+\infty} f^i(x), \quad f^{i+1} = f \circ f^i, \quad \text{and } f^0 = \text{Id}_{\mathcal{D}}.$$

Theorem 6 (Greatest fixed point [2]) *Let $(\mathcal{D}, \oplus, \otimes)$ be a complete dioid, $f : \mathcal{D} \rightarrow \mathcal{D}$ be an upper semi-continuous mapping in this dioid, and \mathcal{Y} the set of fixed points of f . The greatest fixed point of f is*

$$\bigoplus_{y \in \mathcal{Y}} y = f_* \left(\bigoplus_{x \in \mathcal{D}} x \right) = f_*(\top)$$

$$\text{with } f_*(x) = \bigwedge_{i=0}^{+\infty} f^i(x).$$

Definition 19 (Kleene star) *The Kleene star is a mapping denoted $*$. In a complete dioid $(\mathcal{D}, \oplus, \otimes)$, it is defined $\forall a \in \mathcal{D}$ by:*

$$a^* = \bigoplus_{i=0}^{\infty} a^i \quad \text{with } a^{i+1} = a \otimes a^i \quad \text{and } a^0 = e.$$

Remark 10 *The Kleene star can also be applied to (square) matrices in the corresponding complete dioid. For $\mathbf{A} \in \mathcal{D}^{n \times n}$ it is defined by*

$$\mathbf{A}^* = \bigoplus_{i=0}^{\infty} \mathbf{A}^i \quad \text{with} \quad \mathbf{A}^{i+1} = \mathbf{A} \otimes \mathbf{A}^i \quad \text{and} \quad \mathbf{A}^0 = \mathbf{I},$$

with \mathbf{I} being the identity matrix of \otimes , i.e.,

$$[\mathbf{I}]_{ij} = \begin{cases} e & \text{if } i = j \\ \varepsilon & \text{else.} \end{cases}$$

Furthermore, for any partition of

$$\mathbf{A} = \begin{bmatrix} a_{11} & a_{12} \\ a_{21} & a_{22} \end{bmatrix},$$

with a_{11} and a_{22} being square matrices, the following holds [2]:

$$\mathbf{A}^* = \begin{bmatrix} a_{11}^* \oplus a_{11}^* a_{12} (a_{21} a_{11}^* a_{12} \oplus a_{22})^* a_{21} a_{11}^* & a_{11}^* a_{12} (a_{21} a_{11}^* a_{12} \oplus a_{22})^* \\ (a_{21} a_{11}^* a_{12} \oplus a_{22})^* a_{21} a_{11}^* & (a_{21} a_{11}^* a_{12} \oplus a_{22})^* \end{bmatrix}.$$

Example 10 (Solution of $x = ax \oplus b$) According to Theorem 5, the least fixed point of the lower semi-continuous mapping $f : x \mapsto ax \oplus b$ in a complete dioid $(\mathcal{D}, \oplus, \otimes)$ is $x = a^*b$. This can be shown by computing f^* , i.e.,

$$\begin{aligned} f^0(x) &= x \\ f^1(x) &= ax \oplus b \\ f^2(x) &= a(ax \oplus b) \oplus b = a^2x \oplus ab \oplus b \\ f^3(x) &= a^2(ax \oplus b) \oplus ab \oplus b = a^3x \oplus a^2b \oplus ab \oplus b \\ &\vdots \\ f^k(x) &= a^{k-1}(ax \oplus b) \oplus a^{k-2}b \oplus \dots \oplus ab \oplus b \end{aligned}$$

and according to the definition of f^* :

$$\begin{aligned} f^*(x) &= \bigoplus_{i=0}^{+\infty} f^i(x) \\ &= x \oplus ax \oplus a^2x \oplus a^3x \oplus \dots \oplus b \oplus ab \oplus a^2b \oplus a^3b \oplus \dots \\ &= (e \oplus a \oplus a^2 \oplus a^3 \oplus \dots)x \oplus (e \oplus a \oplus a^2 \oplus a^3 \oplus \dots)b \\ &= a^*x \oplus a^*b. \end{aligned}$$

Finally, the least fixed point of $f : x \mapsto ax \oplus b$ is equal to $f^*(\varepsilon)$, i.e.,

$$f^*(\varepsilon) = a^*\varepsilon \oplus a^*b = a^*b.$$

This is also the least solution of inequality $x \succeq ax \oplus b$.

Remark 11 The mapping $L_{A^*} : x \mapsto A^*x$ in a complete dioid $(\mathcal{D}, \oplus, \otimes)$ is a closure mapping (see Def. 16), i.e., according to Rem. 8 the equivalence $x = A^*x \Leftrightarrow x \in \text{Im}L_{A^*}$ holds.

The Kleene star in a complete dioid $(\mathcal{D}, \oplus, \otimes)$ has the following properties $\forall a, b \in \mathcal{D}$:

$$\begin{aligned} (a^*)^* &= a^* \\ a(ba)^* &= (ab)^*a \\ (a \oplus b)^* &= (a^*b)^*a^* = b^*(ab^*)^* = (a \oplus b)^*a^* = b^*(a \oplus b)^* \\ a^*a^* &= a^* \\ (ab^*)^* &= e \oplus a(a \oplus b)^*. \end{aligned}$$

For the proofs and a more extensive list of properties of the Kleene star, the reader is invited to consult [8, 13]. Additionally, some nice properties of the Kleene star in combination with the residual mappings of the left and right product can be derived:

$$a = a^* \Leftrightarrow a = a \wp a \qquad a = a^* \Leftrightarrow a = a \phi a \qquad (1.26)$$

$$a^* \wp x = a^* \wp (a^* \wp x) \qquad x \phi a^* = (x \phi a^*) \phi a^* \qquad (1.27)$$

$$a^*x = a^* \wp (a^*x) \qquad xa^* = (xa^*) \phi a^* \qquad (1.28)$$

$$a^* \wp x = a^* (a^* \wp x) \qquad x \phi a^* = (x \phi a^*) a^*. \qquad (1.29)$$

Moreover,

$$a \wp a = (a \wp a)^* \qquad a \phi a = (a \phi a)^*.$$

Furthermore, in [7] it has been shown that this property also holds for matrices $A \in \mathcal{D}^{p \times n}$ and $A \wp A \in \mathcal{D}^{n \times n}$, i.e.,

$$A \wp A = (A \wp A)^*.$$

Lemma 1 ([2]) Given a matrix $A \in \mathcal{D}^{n \times n}$ and a matrix $x \in \mathcal{D}^{n \times p}$, the following equivalences hold

$$x \preceq A \wp x \Leftrightarrow x \succeq Ax \Leftrightarrow x = A^*x \Leftrightarrow x = A^* \wp x.$$

Lemma 2 ([23]) For two matrices $A, B \in \mathcal{D}^{n \times n}$ with $(\mathcal{D}^{n \times n}, \oplus, \otimes)$ being a complete dioid, the following statements are equivalent:

$$A^* \succeq B^* \Leftrightarrow A^*B^* = B^*A^* = B^* \wp A^* = A^* \phi B^* = A^*.$$

Remark 12 Given two closure mappings $L_{A^*} : x \mapsto A^*x$ and $L_{B^*} : x \mapsto B^*x$, such that $L_{A^*} \succeq L_{B^*}$, i.e., $A^* \succeq B^*$, the following equivalence holds:

$$L_{A^*} \succeq L_{B^*} \Leftrightarrow L_{A^*} \circ L_{B^*} = L_{B^*} \circ L_{A^*} = L_{A^*} \Leftrightarrow \text{Im}L_{A^*} \subset \text{Im}L_{B^*}.$$

1.3.7 Dual residuation

In Sec. 1.3.5 it has been shown how residuation theory can be applied to determine the greatest solution of inequalities like $f(a) \preceq b$. However, it is of course also possible to determine the least solution of inequalities such as $f(a) \succeq b$. The definitions for the so-called dual residuation are analogous to the definitions for the previously introduced residuation.

Definition 20 (Dually residuated mapping) *An isotone mapping $f : \mathcal{D} \rightarrow \mathcal{C}$ with (\mathcal{D}, \preceq) and (\mathcal{C}, \preceq) being ordered sets, is said to be dually residuated, if inequality $f(a) \succeq b$ has a least solution in \mathcal{D} for all $b \in \mathcal{C}$.*

Theorem 7 ([2]) *For an isotone mapping $f : \mathcal{D} \rightarrow \mathcal{C}$ from one complete dioid to another complete dioid, the following statements are equivalent:*

- (i) f is dually residuated
- (ii) $f(\top) = \top$ and f is upper semi-continuous
- (iii) There exists an isotone lower semi-continuous mapping $f^\flat : \mathcal{C} \rightarrow \mathcal{D}$, such that:

$$\begin{aligned} (f \circ f^\flat)(b) &\succeq b \\ (f^\flat \circ f)(a) &\preceq a. \end{aligned}$$

Mapping f^\flat is said to be the dual residual of f .

Theorem 8 ([23]) *For a dually residuated mapping $f : \mathcal{D} \rightarrow \mathcal{C}$ the following equalities hold:*

$$\begin{aligned} f \circ f^\flat \circ f &= f \\ f^\flat \circ f \circ f^\flat &= f^\flat. \end{aligned}$$

1.3.7.1 Dual multiplication

In this section we are interested in determining a “pseudo inverse” of a particular operation denoted \odot , which is the so-called dual multiplication. This operation is not included in the standard definition of idempotent semirings.

Definition 21 (Dual multiplication) *For two matrices $\mathbf{A} \in \mathcal{D}^{p \times n}$ and $\mathbf{B} \in \mathcal{D}^{n \times q}$ in a complete dioid, the dual multiplication $\mathbf{A} \odot \mathbf{B}$ is defined by*

$$[\mathbf{A} \odot \mathbf{B}]_{ij} = \bigwedge_{k=1}^n [\mathbf{A}]_{ik} \odot [\mathbf{B}]_{kj} \quad \forall i = 1, \dots, p; \forall j = 1, \dots, q$$

with the following convention in the scalar case:

$$\begin{aligned} a \odot b &= a \otimes b \quad \forall a, b \in \mathcal{D} \setminus \top \\ x \odot \top &= \top \odot x = \top \quad \forall x \in \mathcal{D}. \end{aligned}$$

In particular, this implies that $\varepsilon \odot \top = \top$, while $\varepsilon \otimes \top = \varepsilon$.

Definition 22 (Dual Kleene star) *The dual Kleene star is a mapping denoted \ast . In a complete dioid $(\mathcal{D}, \oplus, \otimes)$, it is defined for $\mathbf{A} \in \mathcal{D}^{n \times n}$ as:*

$$\mathbf{A}_\ast = \bigwedge_{k=0}^{\infty} \mathbf{A}^{\odot k},$$

where $\mathbf{A}^{\odot 0} = \mathbf{I}^{\odot}$ and $\mathbf{A}^{\odot k} = \mathbf{A} \odot \mathbf{A}^{\odot(k-1)}$, with \mathbf{I}^{\odot} being the identity of the dual multiplication, i.e.,

$$[\mathbf{I}^{\odot}]_{ij} = \begin{cases} e & \text{if } i = j \\ \top & \text{else.} \end{cases}$$

Remark 13 *Mapping $\Lambda_{\mathbf{A}_\ast} : \mathbf{x} \mapsto \mathbf{A}_\ast \odot \mathbf{x}$ in a complete dioid $(\mathcal{D}, \oplus, \otimes)$ is a closure mapping (see Def. 16), i.e., according to Rem 8 the equivalence $\mathbf{x} = \mathbf{A}_\ast \odot \mathbf{x} \Leftrightarrow \mathbf{x} \in \text{Im} \Lambda_{\mathbf{A}_\ast}$ holds.*

Definition 23 *An element $a \in \mathcal{D}$ with $(\mathcal{D}, \oplus, \otimes)$ being a complete dioid, admits a left inverse (respectively a right inverse), if there exists an element b (respectively c), such that $b \otimes a = e$ ($a \otimes c = e$, respectively).*

Lemma 3 ([2]) *Given a scalar $a \in \mathcal{D}$, with $(\mathcal{D}, \oplus, \otimes)$ being a complete dioid, admitting a left inverse b and a right inverse c , the following statement holds*

$$b = c \text{ and both are denoted } a^{-1}.$$

Lemma 4 ([23]) *Given a matrix $\mathbf{A} \in \mathcal{D}^{p \times n}$ and the set \mathcal{X} of elements in $\mathcal{D}^{n \times q}$. If every entry of \mathbf{A} admits an inverse or is equal to ε or \top , the mapping $\Lambda_{\mathbf{A}} : \mathbf{x} \mapsto \mathbf{A} \odot \mathbf{x}$ is upper semi-continuous, i.e.,*

$$\Lambda_{\mathbf{A}} \left(\bigwedge_{\mathbf{x} \in \mathcal{X}} \mathbf{x} \right) = \bigwedge_{\mathbf{x} \in \mathcal{X}} \Lambda_{\mathbf{A}}(\mathbf{x}).$$

Of particular interest is the dual left product, i.e., given two matrices $\mathbf{A} \in \mathcal{D}^{n \times n}$ and $\mathbf{X} \in \mathcal{D}^{n \times n}$ and every entry in \mathbf{A} is either ε or \top , or admits an inverse, then mapping $\Lambda_{\mathbf{A}} : \mathbf{X} \mapsto \mathbf{A} \odot \mathbf{X}$ is dually residuated and the dual residual is denoted:

$$\Lambda_{\mathbf{A}}^b : \mathbf{X} \mapsto \mathbf{A} \blacktriangleright \mathbf{X}$$

with

$$[\mathbf{A} \blacktriangleright \mathbf{X}]_{ij} = \bigoplus_{k=1}^n \left([\mathbf{A}]_{ki} \blacktriangleright [\mathbf{X}]_{kj} \right) = \bigoplus_{k=1}^n \left([\mathbf{A}]_{ki}^{-1} \otimes [\mathbf{X}]_{kj} \right)$$

under the conventions that

$$\varepsilon \blacktriangleright \varepsilon = \varepsilon \text{ and } \top \blacktriangleright x = \varepsilon, \varepsilon \blacktriangleright x = \top \quad \forall x.$$

Remark 14 *An important thing to realize is that*

$$a \succeq b \Rightarrow a \blacktriangleright x \preceq b \blacktriangleright x \quad \forall a, b, x \in \mathcal{D}.$$

Furthermore, given that b admits an inverse and due to the associativity of multiplication in dioids, the following statement is true

$$b \blacktriangleright (a \otimes c) = (b \blacktriangleright a) \otimes c.$$

This can easily be shown by rewriting the equation, i.e.,

$$b \blacktriangleright (a \otimes c) = b^{-1} \otimes (a \otimes c) = (b^{-1} \otimes a) \otimes c.$$

Remark 15 *Of course residuation theory can also be applied to determine the dual residual of the mapping $\Gamma_A : X \mapsto X \odot A$, with $A, X \in \mathcal{D}^{n \times n}$. It is denoted*

$$\Gamma_A^{\blacktriangleright} : X \mapsto X \blacktriangleright A$$

with

$$[X \blacktriangleright A]_{ij} = \bigoplus_{k=1}^n ([X]_{ik} \blacktriangleright [A]_{jk}) = \bigoplus_{k=1}^n ([X]_{ik} \otimes [A]_{jk}^{-1})$$

with the conventions that

$$x \blacktriangleright \top = \varepsilon, x \blacktriangleright \varepsilon = \top, \text{ and } \varepsilon \blacktriangleright \varepsilon = \varepsilon.$$

The dual left and right “division” have the following properties [23]:

$$a \blacktriangleright (x \oplus y) = a \blacktriangleright x \oplus a \blacktriangleright y \quad (x \oplus y) \blacktriangleright a = x \blacktriangleright a \oplus y \blacktriangleright a \quad (1.30)$$

$$a \blacktriangleright (x \wedge y) \preceq a \blacktriangleright x \wedge a \blacktriangleright y \quad (x \wedge y) \blacktriangleright a \preceq x \blacktriangleright a \wedge y \blacktriangleright a \quad (1.31)$$

$$(x \oplus y) \blacktriangleright a \preceq x \blacktriangleright a \wedge y \blacktriangleright a \quad a \blacktriangleright (x \oplus y) \preceq a \blacktriangleright x \wedge a \blacktriangleright y \quad (1.32)$$

$$a \odot (a \blacktriangleright x) \succeq x \quad (x \blacktriangleright a) \odot a \succeq x \quad (1.33)$$

$$a \blacktriangleright (a \odot x) \preceq x \quad (x \odot a) \blacktriangleright a \preceq x \quad (1.34)$$

$$a \odot (a \blacktriangleright (a \odot x)) = a \odot x \quad ((x \odot a) \blacktriangleright a) \odot a = x \odot a \quad (1.35)$$

$$a \blacktriangleright (a \odot (a \blacktriangleright x)) = a \blacktriangleright x \quad ((x \blacktriangleright a) \odot a) \blacktriangleright a = x \blacktriangleright a \quad (1.36)$$

$$(a \odot b) \blacktriangleright x = b \blacktriangleright (a \blacktriangleright x) \quad x \blacktriangleright (b \odot a) = (x \blacktriangleright a) \blacktriangleright b \quad (1.37)$$

$$(a \blacktriangleright x) \blacktriangleright b = a \blacktriangleright (x \blacktriangleright b) \quad b \blacktriangleright (x \blacktriangleright a) = (b \blacktriangleright x) \blacktriangleright a \quad (1.38)$$

Lemma 5 ([5]) *Similar to Lem. 1 it is possible to show that the following equivalences hold for two matrices $A \in \mathcal{D}^{n \times n}$ and $x \in \mathcal{D}^{n \times p}$*

$$x \preceq A \odot x \Leftrightarrow x \succeq A \blacktriangleright x \Leftrightarrow x = A_* \blacktriangleright x \Leftrightarrow x = A_* \odot x.$$

Lemma 6 ([5]) *Given three matrices $A \in \mathcal{D}^{n \times p}$, $X \in \mathcal{D}^{p \times q}$, and $B \in \mathcal{D}^{n \times n}$. If every entry of B is either ε or \top or admits an inverse the following property holds*

$$B \blacktriangleright (A \otimes X) = (B \blacktriangleright A) \otimes X. \quad (1.39)$$

1.3.8 Idempotent semirings of formal power series

Definition 24 (Formal power series) *A formal power series in p (commutative) variables, denoted z_1 to z_p , with coefficients in a semiring \mathcal{D} , is a mapping s defined from \mathbb{Z}^p into \mathcal{D} : $\forall k = (k_1, \dots, k_p) \in \mathbb{Z}^p$, $s(k)$ represents the coefficient of $z_1^{k_1} \dots z_p^{k_p}$ and (k_1, \dots, k_p) are the exponents. Another equivalent representation is*

$$s(z_1, \dots, z_p) = \bigoplus_{k \in \mathbb{Z}^p} s(k) z_1^{k_1} \dots z_p^{k_p}$$

Definition 25 (Support, degree, and valuation of a formal power series) *The support of a formal power series is defined as*

$$\text{supp}(s) = \{(k_1, \dots, k_p) \in \mathbb{Z}^p \mid s(k_1, \dots, k_p) \neq \varepsilon\}.$$

The degree $\text{deg}(s)$ (respectively valuation $\text{val}(s)$) is the least upper bound (respectively greatest lower bound) of $\text{supp}(s)$ in the complete lattice $(\overline{\mathbb{Z}}^p, \oplus, \wedge)$, where $\overline{\mathbb{Z}} = \mathbb{Z} \cup \{-\infty, +\infty\}$.

A series with a finite support is called a polynomial and a monomial if there is only one element in the series.

Definition 26 (Idempotent semiring of series) *The set of formal power series with coefficients in an idempotent semiring \mathcal{D} endowed with the following sum and Cauchy product*

$$\begin{aligned} s \oplus s' : (s \oplus s')(k) &= s(k) \oplus s'(k) \\ s \otimes s' : (s \otimes s')(k) &= \bigoplus_{i+j=k} s(i) \otimes s'(j), \end{aligned}$$

is an idempotent semiring denoted $\mathcal{D}[[z_1, \dots, z_p]]$. If \mathcal{D} is complete, $\mathcal{D}[[z_1, \dots, z_p]]$ is complete. The greatest lower bound of two series is given by

$$s \wedge s' : (s \wedge s')(k) = s(k) \wedge s'(k).$$

Definition 27 (γ -transform) *The γ -transform of a discrete signal $s(k)$ with $s : \mathbb{Z} \rightarrow \mathcal{D}$ and $\mathcal{D} = (\overline{\mathbb{Z}}_{\max}, \oplus, \otimes)$ is defined by*

$$s(\gamma) = \bigoplus_{k \in \mathbb{Z}} s(k) \otimes \gamma^k.$$

Remark 16 The γ -transform is analogous to the z -transform in classical systems theory, which allows to describe a discrete signal by a formal power series.

Remark 17 Since $s(\gamma) \otimes \gamma = \bigoplus_{k \in \mathbb{Z}} s(k) \otimes \gamma^{k+1} = \bigoplus_{k \in \mathbb{Z}} s(k-1) \otimes \gamma^k$, γ can be seen as a backward shift operator.

Definition 28 (Idempotent semiring $\overline{\mathbb{Z}}_{\max}[\gamma]$) The set of formal power series in γ with exponents in \mathbb{Z} and coefficients in $\overline{\mathbb{Z}}_{\max}$ is an idempotent semiring and is denoted $\overline{\mathbb{Z}}_{\max}[\gamma]$. The zero element is the series $\varepsilon(\gamma) = \bigoplus_{k \in \mathbb{Z}} \varepsilon \gamma^k$, where $\varepsilon = -\infty$, the zero element of $(\overline{\mathbb{Z}}_{\max}, \oplus, \otimes)$. The unit element is the formal series $e(\gamma) = e \gamma^0$, where $e = 0$ is the unit element of $(\overline{\mathbb{Z}}_{\max}, \oplus, \otimes)$. The sum and product in $\overline{\mathbb{Z}}_{\max}[\gamma]$ are defined by

$$\begin{aligned} s_1(\gamma) \oplus s_2(\gamma) &= \bigoplus_{k \in \mathbb{Z}} (s_1(k) \oplus s_2(k)) \gamma^k \\ s_1(\gamma) \otimes s_2(\gamma) &= \bigoplus_{k_1+k_2=k} (s_1(k_1) \otimes s_2(k_2)) \gamma^k. \end{aligned}$$

Example 11 Given two formal power series in $\overline{\mathbb{Z}}_{\max}[\gamma]$, $s_1(\gamma) = 3\gamma^2$ and $s_2(\gamma) = 0\gamma^1 \oplus 2\gamma^2$, their sum and product are

$$\begin{aligned} s_1(\gamma) \oplus s_2(\gamma) &= 3\gamma^2 \oplus 0\gamma^1 \oplus 2\gamma^2 = 0\gamma^1 \oplus (3 \oplus 2)\gamma^2 = 0\gamma^1 \oplus 3\gamma^2 \\ s_1(\gamma) \otimes s_2(\gamma) &= 3\gamma^2 \otimes (0\gamma^1 \oplus 2\gamma^2) = (3 \otimes 0)\gamma^3 \oplus (3 \otimes 2)\gamma^4 = 3\gamma^3 \oplus 5\gamma^4. \end{aligned}$$

Remark 18 In general, we will only write the elements of a power series which have a non-zero coefficient, e.g., $s_1(\gamma) = \dots \oplus \varepsilon \gamma^0 \oplus \varepsilon \gamma^1 \oplus 3\gamma^2 \oplus \varepsilon \gamma^3 \oplus \varepsilon \gamma^4 \oplus \dots = 3\gamma^2$.

Definition 29 (δ -transform) Analogously to the γ -transform, the δ -transform of a discrete signal $s(t)$ with $s : \mathbb{Z} \rightarrow \mathcal{D}$ and $\mathcal{D} = (\overline{\mathbb{Z}}_{\min}, \oplus, \otimes)$, i.e., min-plus algebra, is defined by

$$s(\delta) = \bigoplus_{t \in \mathbb{Z}} s(t) \otimes \delta^t.$$

Definition 30 (Idempotent semiring $\overline{\mathbb{Z}}_{\min}[\delta]$) The set of formal power series in δ with exponents in \mathbb{Z} and coefficients in $\overline{\mathbb{Z}}_{\min}$ has a dioid structure and is denoted $\overline{\mathbb{Z}}_{\min}[\delta]$. The zero and unit element are $\varepsilon(\delta) = \bigoplus_{t \in \mathbb{Z}} \varepsilon \delta^t$, with $\varepsilon = +\infty$, and $e(\delta) = e \delta^0$, with $e = 0$, respectively. Addition and multiplication in $\overline{\mathbb{Z}}_{\min}[\delta]$ are defined by

$$\begin{aligned} s_1(\delta) \oplus s_2(\delta) &= \bigoplus_{t \in \mathbb{Z}} (s_1(t) \oplus s_2(t)) \delta^t \\ s_1(\delta) \otimes s_2(\delta) &= \bigoplus_{t_1+t_2=t} (s_1(t_1) \otimes s_2(t_2)) \delta^t. \end{aligned}$$

Example 12 Given two formal power series in $\overline{\mathbb{Z}}_{\min}[\delta]$, $s_1(\delta) = 2\delta^3$ and $s_2(\delta) = 1\delta^0 \oplus 2\delta^2$, their sum and product are

$$s_1(\delta) \oplus s_2(\delta) = 2\delta^3 \oplus 1\delta^0 \oplus 2\delta^2 = 1\delta^0 \oplus 2\delta^2 \oplus 2\delta^3$$

$$s_1(\delta) \otimes s_2(\delta) = 2\delta^3 \otimes (1\delta^0 \oplus 2\delta^2) = (2 \otimes 1)\delta^3 \oplus (2 \otimes 2)\delta^5 = 3\delta^3 \oplus 4\delta^5.$$

Definition 31 (Idempotent semiring $\mathbb{B}[\gamma, \delta]$) The dioid of formal power series in two variables γ and δ with Boolean coefficients, i.e., $\mathbb{B} = \{\varepsilon, e\}$, and exponents in \mathbb{Z} is denoted $\mathbb{B}[\gamma, \delta]$. A series $s \in \mathbb{B}[\gamma, \delta]$ is represented by

$$s(\gamma, \delta) = \bigoplus_{k,t \in \mathbb{Z}} s(k,t) \gamma^k \delta^t,$$

with $s(k,t) \in \mathbb{B}$. $\mathbb{B}[\gamma, \delta]$ is a complete and commutative dioid. The zero and unit element are $\varepsilon(\gamma, \delta) = \bigoplus_{k,t \in \mathbb{Z}} \varepsilon \gamma^k \delta^t$ and $e(\gamma, \delta) = \gamma^0 \delta^0$, respectively.

Example 13 A series can graphically be represented in the \mathbb{Z}^2 -plane, with the exponents of γ on the horizontal axis and the exponents of δ on the vertical axis, by drawing a black dot for all elements with non-zero coefficient. One possible series in $\mathbb{B}[\gamma, \delta]$ is $s(\gamma, \delta) = \gamma^1 \delta^0 \oplus \gamma^2 \delta^2 \oplus \gamma^2 \delta^3 \oplus \gamma^4 \delta^3$. The corresponding graphical representation of this series is given in Fig. 1.6.

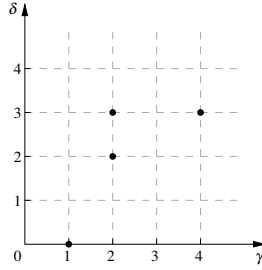

Fig. 1.6 Graphical representation of the series $s(\gamma, \delta) = \gamma^1 \delta^0 \oplus \gamma^2 \delta^2 \oplus \gamma^2 \delta^3 \oplus \gamma^4 \delta^3 \in \mathbb{B}[\gamma, \delta]$.

1.3.8.1 Quotient dioids

Definition 32 (Congruence) Let \equiv denote an equivalence relation on a dioid $(\mathcal{D}, \oplus, \otimes)$. A congruence relation is an equivalence relation which satisfies

$$a \equiv b \Rightarrow \begin{cases} a \oplus c \equiv b \oplus c \\ a \otimes c \equiv b \otimes c \end{cases} \quad \forall a, b, c \in \mathcal{D}.$$

Given a dioid $(\mathcal{D}, \oplus, \otimes)$ equipped with an equivalence relation \equiv . The equivalence class represented by an element $a \in \mathcal{D}$ is denoted $[a]_{\equiv}$, i.e.,

$$[a]_{\equiv} = \{x \in \mathcal{D} \mid x \equiv a\}.$$

The set of all equivalence classes is the *quotient* of the dioid $(\mathcal{D}, \oplus, \otimes)$.

Lemma 7 (Quotient dioid [2]) *The quotient of a dioid $(\mathcal{D}, \oplus, \otimes)$ with respect to a congruence relation \equiv is itself a dioid. It is called quotient dioid and is denoted \mathcal{D}/\equiv . For addition and multiplication the following properties hold*

$$\begin{aligned} [a]_{\equiv} \oplus [b]_{\equiv} &= [a \oplus b]_{\equiv} \\ [a]_{\equiv} \otimes [b]_{\equiv} &= [a \otimes b]_{\equiv}. \end{aligned}$$

Definition 33 (Idempotent semiring $\mathcal{M}_{in}^{ax}[\gamma, \delta]$) *The quotient dioid of $\mathbb{B}[\gamma, \delta]$ with respect to the congruence relation in $\mathbb{B}[\gamma, \delta]$*

$$a \equiv b \Leftrightarrow \gamma^* (\delta^{-1})^* a = \gamma^* (\delta^{-1})^* b,$$

is denoted $\mathcal{M}_{in}^{ax}[\gamma, \delta]$, i.e., $\mathcal{M}_{in}^{ax}[\gamma, \delta] = \mathbb{B}[\gamma, \delta] /_{\gamma^* (\delta^{-1})^*}$, where $*$ refers to the Kleene star. $\mathcal{M}_{in}^{ax}[\gamma, \delta]$ constitutes a complete dioid and the zero and unit elements are $\varepsilon(\gamma, \delta) = \bigoplus_{k,t \in \mathbb{Z}} \varepsilon \gamma^k \delta^t$ and $e(\gamma, \delta) = \gamma^0 \delta^0$, respectively.

Remark 19 *In the following, the dioid $\mathcal{M}_{in}^{ax}[\gamma, \delta]$ will be used to describe how often events can occur within a specific time. For example, the monomial $\gamma^k \delta^t$ is to be interpreted as: “The $(k+1)$ -st occurrence of the event is at time t at the earliest.”*

Graphically, a monomial $\gamma^k \delta^t \in \mathcal{M}_{in}^{ax}[\gamma, \delta]$ cannot be represented as a point in the \mathbb{Z}^2 -plane (as it was the case for $\gamma^k \delta^t \in \mathbb{B}[\gamma, \delta]$). This is due to the fact that in $\mathcal{M}_{in}^{ax}[\gamma, \delta]$, $\gamma^k \delta^t \equiv \gamma^k \delta^t \otimes \gamma^* (\delta^{-1})^*$. Rewriting the right hand side of this equivalence results in

$$\begin{aligned} \gamma^k \delta^t &\equiv \gamma^k \delta^t \underbrace{\left(\bigoplus_{i=0}^{\infty} \gamma^i \right)}_{\gamma^*} \underbrace{\left(\bigoplus_{j=0}^{\infty} (\delta^{-1})^j \right)}_{(\delta^{-1})^*} \\ &= \gamma^k \delta^t \left(\bigoplus_{i=0}^{\infty} \gamma^i \right) \left(\bigoplus_{j=0}^{\infty} \delta^{-j} \right) \\ &= \bigoplus_{i=0}^{\infty} \bigoplus_{j=0}^{\infty} \gamma^{k+i} \delta^{t-j}. \end{aligned}$$

Consequently, the monomial $\gamma^k \delta^t \in \mathcal{M}_{in}^{ax}[\gamma, \delta]$ represents the set $\{\gamma^n \delta^m \in \mathbb{B}[\gamma, \delta] \mid n \geq k, m \leq t\}$. Graphically speaking, every monomial $\gamma^k \delta^t \in \mathcal{M}_{in}^{ax}[\gamma, \delta]$ represents all points in the \mathbb{Z}^2 -plane that are “south-east” of the point (k, t) . Consequently, a polynomial in $\mathcal{M}_{in}^{ax}[\gamma, \delta]$ is graphically represented as the union of south-east cones of the single monomials composing the polynomial.

Example 14 *A possible series in $\mathcal{M}_{in}^{ax}[\gamma, \delta]$ is $s(\gamma, \delta) = \gamma^1 \delta^0 \oplus \gamma^2 \delta^2 \oplus \gamma^4 \delta^3$. Its corresponding graphical representation is given in Fig. 1.7.*

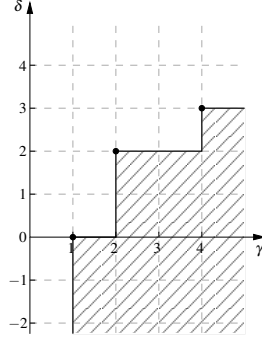

Fig. 1.7 Graphical representation of the series $s(\gamma, \delta) = \gamma^1 \delta^0 \oplus \gamma^2 \delta^2 \oplus \gamma^4 \delta^3 \in \mathcal{M}_{in}^{ax}[\gamma, \delta]$.

Remark 20 The graphical representation allows for a straightforward visualization of the partial order \preceq in $\mathcal{M}_{in}^{ax}[\gamma, \delta]$. Namely, $s_1 \preceq s_2$, if the graphical representation of s_1 is contained in the respective representation of s_2 . Consequently, the zero element of $\mathcal{M}_{in}^{ax}[\gamma, \delta]$ needs to be the bottom right element and the top element the top left element. Therefore (and for simplicity reasons), these elements are often denoted $\varepsilon = \gamma^{+\infty} \delta^{-\infty}$ and $\top = \gamma^{-\infty} \delta^{+\infty}$, respectively.

Remark 21 (Minimal representation) As mentioned before, two series s_1 and s_2 in $\mathcal{M}_{in}^{ax}[\gamma, \delta]$ belong to an equivalence class if $s_1 \otimes \gamma^* (\delta^{-1})^* = s_2 \otimes \gamma^* (\delta^{-1})^*$. Graphically speaking this means all series of an equivalence class “cover” the same area in the \mathbb{Z}^2 -plane. For example, the series

$$\begin{aligned} s_1 &= \gamma^1 \delta^0 \oplus \gamma^2 \delta^2 \oplus \gamma^4 \delta^3 \\ s_2 &= \gamma^1 \delta^0 \oplus \gamma^2 \delta^2 \oplus \gamma^3 \delta^2 \oplus \gamma^4 \delta^3 \\ s_3 &= \gamma^1 \delta^0 \oplus \gamma^2 \delta^2 \oplus \gamma^3 \delta^2 \oplus \gamma^4 \delta^3 \oplus \gamma^6 \delta^1 \end{aligned}$$

are all equivalent with respect to the congruence relation $\gamma^* (\delta^{-1})^*$. However, series s_1 is the so-called minimal representation, as its support consists of a minimal number of elements. In the following the minimal representation is (always) used to denote an equivalence class.

For monomials in $\mathcal{M}_{in}^{ax}[\gamma, \delta]$ the following rules apply for addition, multiplication and the greatest lower bound:

$$\begin{aligned} \gamma^k \delta^t \oplus \gamma^l \delta^t &= \gamma^{\min(k,l)} \delta^t \\ \gamma^k \delta^t \oplus \gamma^k \delta^\tau &= \gamma^k \delta^{\max(t,\tau)} \\ \gamma^k \delta^t \otimes \gamma^l \delta^\tau &= \gamma^{(k+l)} \delta^{(t+\tau)} \\ \gamma^k \delta^t \wedge \gamma^l \delta^\tau &= \gamma^{\max(k,l)} \delta^{\min(t,\tau)}. \end{aligned}$$

Graphically, for monomials in $\mathcal{M}_{in}^{ax}[\gamma, \delta]$

- addition: $\gamma^k \delta^t \oplus \gamma^l \delta^\tau$ refers to the union of south-east cones of (k, t) and (l, τ)
- multiplication: $\gamma^k \delta^t \otimes \gamma^l \delta^\tau$ refers to a south-east cone of $(k+l, t+\tau)$
- greatest lower bound: $\gamma^k \delta^t \wedge \gamma^l \delta^\tau$ refers to the intersection of the two south-east cones of (k, t) and (l, τ) , i.e., the south-east cone of $(\max(k, l), \min(t, \tau))$.

The graphical representation of these operations is given in Fig. 1.8.

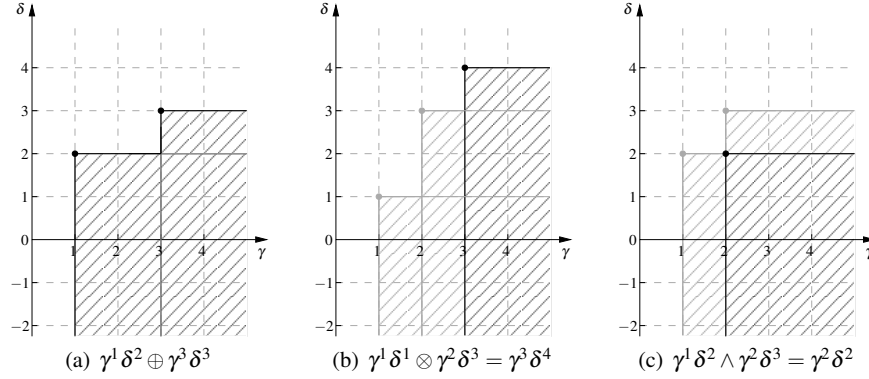

Fig. 1.8 Graphical representation of operations in $\mathcal{M}_{in}^{ax}[\gamma, \delta]$.

Definition 34 (Causality of a series in $\mathcal{M}_{in}^{ax}[\gamma, \delta]$) A series $s \in \mathcal{M}_{in}^{ax}[\gamma, \delta]$ is causal if $s = \varepsilon$ or if both $\text{val}_\gamma(s) \geq 0$ and $s \succeq \gamma^{\text{val}_\gamma(s)} \delta^0$, where $\text{val}_\gamma(s)$ refers to the valuation in γ of series s . Consequently, the exponents of all monomials composing a causal series s are greater or equal to zero.

The set of causal elements of $\mathcal{M}_{in}^{ax}[\gamma, \delta]$ has a complete semiring structure and is denoted $\mathcal{M}_{in}^{ax+}[\gamma, \delta]$. Obviously, $\mathcal{M}_{in}^{ax+}[\gamma, \delta]$ is a complete sub-dioid of $\mathcal{M}_{in}^{ax}[\gamma, \delta]$.

Remark 22 (Causality of a matrix in $\mathcal{M}_{in}^{ax}[\gamma, \delta]$) A matrix A with entries in $\mathcal{M}_{in}^{ax}[\gamma, \delta]$ is causal, if all its entries are causal.

Definition 35 (Causal projection) The canonical injection $\Pi_{\mathcal{M}_{in}^{ax+}[\gamma, \delta]} : \mathcal{M}_{in}^{ax+}[\gamma, \delta] \rightarrow \mathcal{M}_{in}^{ax}[\gamma, \delta]$ is residuated and its residual is denoted $\text{Pr}_{caus} : \mathcal{M}_{in}^{ax}[\gamma, \delta] \rightarrow \mathcal{M}_{in}^{ax+}[\gamma, \delta]$. Formally, the series $\text{Pr}_{caus}(s)$ is the greatest causal series less or equal to series $s \in \mathcal{M}_{in}^{ax}[\gamma, \delta]$. It can be computed by

$$\text{Pr}_{caus} \left(\bigoplus_{k,t \in \mathbb{Z}} s(k,t) \gamma^k \delta^t \right) = \bigoplus_{k,t \in \mathbb{Z}} s^+(k,t) \gamma^k \delta^t$$

with

$$s^+(k,t) = \begin{cases} s(k,t) & \text{if } (k,t) \geq (0,0) \\ \varepsilon & \text{otherwise.} \end{cases}$$

Example 15 (Causal projection of a series) Given a non-causal series $s = \gamma^{-4}\delta^{-1} \oplus \gamma^{-2}\delta^2 \oplus \gamma^2\delta^3 \oplus \gamma^4\delta^4 \in \mathcal{M}_{in}^{ax}[\gamma, \delta]$. Its causal projection $s_{caus} = \text{Pr}_{caus}(s) = \gamma^0\delta^2 \oplus \gamma^2\delta^3 \oplus \gamma^4\delta^4 \in \mathcal{M}_{in}^{ax+}[\gamma, \delta]$. Graphically, the minimal representation of the causal projection of a series is the series that covers the same area in the first quadrant but is devoid of any points in the other quadrants. In Fig. 1.9 the series s and its causal projection $\text{Pr}_{caus}(s)$ are shown.

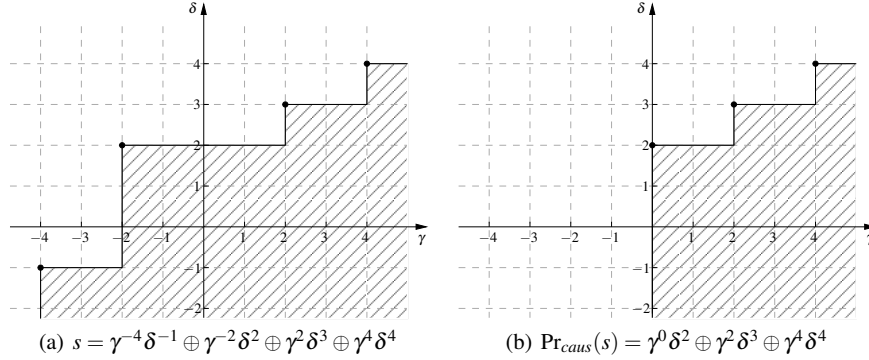

Fig. 1.9 Causal projection of a (non-causal) series $s \in \mathcal{M}_{in}^{ax}[\gamma, \delta]$.

Definition 36 (Periodic series in $\mathcal{M}_{in}^{ax}[\gamma, \delta]$) A series $s \in \mathcal{M}_{in}^{ax}[\gamma, \delta]$ is said to be periodic if it can be written as $s = p \oplus q \otimes r^*$, where p is a polynomial referring to a transient phase, e.g., the start-up of the system, q is a polynomial representing the periodical behavior; i.e., the pattern that will be repeated periodically, and $r = \gamma^v \delta^\tau$ is a monomial describing the periodicity. Then the ratio v/τ is the asymptotic slope (or throughput) of the series, i.e., once the periodic regime is reached an event occurs v times every τ time units.

Example 16 (Periodic series in $\mathcal{M}_{in}^{ax}[\gamma, \delta]$) Considering the series $s \in \mathcal{M}_{in}^{ax}[\gamma, \delta]$

$$s = e \oplus \gamma\delta^2 \oplus \gamma^3\delta^3 \oplus \gamma^4\delta^5 \oplus \gamma^5\delta^6 \oplus \gamma^6\delta^8 \oplus \gamma^8\delta^9 \oplus \gamma^9\delta^{11} \oplus \gamma^{11}\delta^{12} \oplus \gamma^{12}\delta^{14} \oplus \dots$$

This series is a periodic series and can be written

$$s = \underbrace{e \oplus \gamma\delta^2 \oplus \gamma^3\delta^3 \oplus \gamma^4\delta^5}_p \oplus \underbrace{(\gamma^5\delta^6 \oplus \gamma^6\delta^8)}_q \underbrace{(\gamma^3\delta^3)^*}_{r^*}.$$

The graphical representation of this series is given in Fig. 1.10.

Definition 37 (Realizability of a series in $\mathcal{M}_{in}^{ax}[\gamma, \delta]$) A series $s \in \mathcal{M}_{in}^{ax}[\gamma, \delta]$ is said to be realizable if there exist two square ($n \times n$) matrices A_1, A_2 with Boolean

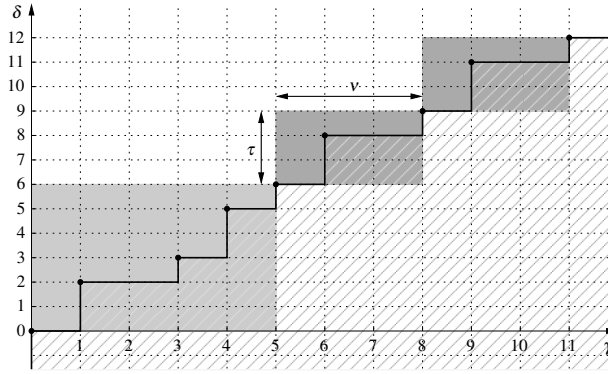

Fig. 1.10 Graphical representation of a periodic series in $\mathcal{M}_{in}^{ax}[\gamma, \delta]$.

entries and two $(1 \times n)$ respectively $(n \times 1)$ matrices C and B with Boolean entries such that $s = C(\gamma A_1 \oplus \delta A_2)^* B$.

Remark 23 (Realizability of a matrix in $\mathcal{M}_{in}^{ax}[\gamma, \delta]$) A matrix $A \in \mathcal{M}_{in}^{ax}[\gamma, \delta]$ is said to be realizable if all its entries are realizable.

Theorem 9 (Causality, Periodicity, Realizability [2]) Given a series $s \in \mathcal{M}_{in}^{ax}[\gamma, \delta]$, the following statements are equivalent:

- s is causal and periodic
- s is realizable.

1.4 Dioid model of timed event graphs

Recall our example of a manufacturing system introduced in Sec. 1.1. The corresponding TEG modeling this system is given in Fig. 1.4, and the recursive equations for the earliest possible firing instants have been determined in (1.9)–(1.14). Rewriting these equations in max-plus algebra, i.e., in the dioid $(\overline{\mathbb{Z}}_{\max}, \oplus, \otimes)$, we get

$$\begin{aligned} x_1(k) &= u_1(k) \oplus x_2(k-2) \\ x_2(k) &= 10x_1(k) \\ x_3(k) &= u_2(k) \oplus x_4(k-1) \\ x_4(k) &= 4x_3(k) \\ x_5(k) &= u_3(k) \oplus 1x_2(k) \oplus 1x_4(k) \oplus x_6(k-1) \\ x_6(k) &= 3x_5(k) \end{aligned}$$

and the output $y(k) \in \overline{\mathbb{Z}}_{\max}$ is

$$y(k) = x_6(k).$$

This can be rewritten in matrix-vector form with $\mathbf{x}(k) = [x_1(k) x_2(k) x_3(k) x_4(k) x_5(k) x_6(k)]^T$ and $\mathbf{u}(k) = [u_1(k) u_2(k) u_3(k)]^T$

$$\mathbf{x}(k) = \mathbf{A}_0 \mathbf{x}(k) \oplus \mathbf{A}_1 \mathbf{x}(k-1) \oplus \mathbf{A}_2 \mathbf{x}(k-2) \oplus \mathbf{B} \mathbf{u}(k) \quad (1.40)$$

$$y(k) = \mathbf{C} \mathbf{x}(k) \quad (1.41)$$

with

$$\mathbf{A}_0 = \begin{bmatrix} \varepsilon & \varepsilon & \varepsilon & \varepsilon & \varepsilon & \varepsilon \\ 10 & \varepsilon & \varepsilon & \varepsilon & \varepsilon & \varepsilon \\ \varepsilon & \varepsilon & \varepsilon & \varepsilon & \varepsilon & \varepsilon \\ \varepsilon & \varepsilon & 4 & \varepsilon & \varepsilon & \varepsilon \\ \varepsilon & 1 & \varepsilon & 1 & \varepsilon & \varepsilon \\ \varepsilon & \varepsilon & \varepsilon & \varepsilon & 3 & \varepsilon \end{bmatrix}, \quad \mathbf{A}_1 = \begin{bmatrix} \varepsilon & \varepsilon & \varepsilon & \varepsilon & \varepsilon & \varepsilon \\ \varepsilon & \varepsilon & \varepsilon & \varepsilon & \varepsilon & \varepsilon \\ \varepsilon & \varepsilon & \varepsilon & e & \varepsilon & \varepsilon \\ \varepsilon & \varepsilon & \varepsilon & \varepsilon & \varepsilon & \varepsilon \\ \varepsilon & \varepsilon & \varepsilon & \varepsilon & e & \varepsilon \\ \varepsilon & \varepsilon & \varepsilon & \varepsilon & \varepsilon & \varepsilon \end{bmatrix}, \quad \mathbf{A}_2 = \begin{bmatrix} \varepsilon & e & \varepsilon & \varepsilon & \varepsilon & \varepsilon \\ \varepsilon & \varepsilon & \varepsilon & \varepsilon & \varepsilon & \varepsilon \\ \varepsilon & \varepsilon & \varepsilon & \varepsilon & \varepsilon & \varepsilon \\ \varepsilon & \varepsilon & \varepsilon & \varepsilon & \varepsilon & \varepsilon \\ \varepsilon & \varepsilon & \varepsilon & \varepsilon & \varepsilon & \varepsilon \\ \varepsilon & \varepsilon & \varepsilon & \varepsilon & \varepsilon & \varepsilon \end{bmatrix}$$

$$\mathbf{B} = \begin{bmatrix} e & \varepsilon & \varepsilon \\ \varepsilon & \varepsilon & \varepsilon \\ \varepsilon & e & \varepsilon \\ \varepsilon & \varepsilon & \varepsilon \\ \varepsilon & \varepsilon & e \\ \varepsilon & \varepsilon & \varepsilon \end{bmatrix}, \quad \text{and} \quad \mathbf{C} = [\varepsilon \ \varepsilon \ \varepsilon \ \varepsilon \ \varepsilon \ e].$$

Clearly, the obtained equations are linear with respect to max-plus algebra. However, the linear system equations are implicit, i.e., $\mathbf{x}(k) = f(\mathbf{x}(k), \dots)$. But, recalling the fixpoint theorem (see Theorem 5), it is possible to obtain the smallest fixed point of an implicit equation by using the Kleene star (see Def. 19 and Ex. 10). Formally, the smallest fixed point of $x = ax \oplus b$ is $x = a^*b$ with a^* being the Kleene star of a . Applying this to our example results in

$$\begin{aligned} \mathbf{x}(k) &= \mathbf{A}_0^* (\mathbf{A}_1 \mathbf{x}(k-1) \oplus \mathbf{A}_2 \mathbf{x}(k-2) \oplus \mathbf{B} \mathbf{u}(k)) \\ &= \mathbf{A}_0^* \mathbf{A}_1 \mathbf{x}(k-1) \oplus \mathbf{A}_0^* \mathbf{A}_2 \mathbf{x}(k-2) \oplus \mathbf{A}_0^* \mathbf{B} \mathbf{u}(k) \\ y(k) &= \mathbf{C} \mathbf{x}(k), \end{aligned}$$

with

$$\begin{aligned}
A_0^* &= \begin{bmatrix} e & \varepsilon & \varepsilon & \varepsilon & \varepsilon & \varepsilon \\ 10 & e & \varepsilon & \varepsilon & \varepsilon & \varepsilon \\ \varepsilon & e & e & \varepsilon & \varepsilon & \varepsilon \\ \varepsilon & \varepsilon & 4 & e & \varepsilon & \varepsilon \\ 11 & 1 & 5 & 1 & e & \varepsilon \\ 14 & 4 & 8 & 4 & 3 & e \end{bmatrix}, \quad A_0^*A_1 = \begin{bmatrix} \varepsilon & \varepsilon & \varepsilon & \varepsilon & \varepsilon & \varepsilon \\ \varepsilon & \varepsilon & \varepsilon & \varepsilon & \varepsilon & \varepsilon \\ \varepsilon & \varepsilon & \varepsilon & e & \varepsilon & \varepsilon \\ \varepsilon & \varepsilon & \varepsilon & 4 & \varepsilon & \varepsilon \\ \varepsilon & \varepsilon & \varepsilon & 5 & \varepsilon & e \\ \varepsilon & \varepsilon & \varepsilon & 8 & \varepsilon & 3 \end{bmatrix}, \quad A_0^*A_2 = \begin{bmatrix} \varepsilon & e & \varepsilon & \varepsilon & \varepsilon & \varepsilon \\ \varepsilon & 10 & \varepsilon & \varepsilon & \varepsilon & \varepsilon \\ \varepsilon & \varepsilon & \varepsilon & \varepsilon & \varepsilon & \varepsilon \\ \varepsilon & \varepsilon & \varepsilon & \varepsilon & \varepsilon & \varepsilon \\ \varepsilon & 11 & \varepsilon & \varepsilon & \varepsilon & \varepsilon \\ \varepsilon & 14 & \varepsilon & \varepsilon & \varepsilon & \varepsilon \end{bmatrix} \\
A_0^*B &= \begin{bmatrix} e & \varepsilon & \varepsilon \\ 10 & \varepsilon & \varepsilon \\ \varepsilon & e & \varepsilon \\ \varepsilon & 4 & \varepsilon \\ 11 & 5 & e \\ 14 & 8 & 3 \end{bmatrix}.
\end{aligned}$$

Thus, we obtained a linear explicit recurrence relation of second order for the earliest firing times of the involved transitions. By suitably augmenting the vector x , e.g., $\tilde{x}(k) = [x(k)^T \ x(k-1)^T]^T$, it is possible to obtain a first order recurrence relation. Formally we get

$$\begin{aligned}
\tilde{x}(k) &= \underbrace{\begin{bmatrix} A_0^*A_1 & A_0^*A_2 \\ I & \mathcal{E} \end{bmatrix}}_{\tilde{A}} \tilde{x}(k-1) \oplus \underbrace{\begin{bmatrix} A_0^*B \\ \mathcal{E} \end{bmatrix}}_{\tilde{B}} u(k) \\
y(k) &= \underbrace{\begin{bmatrix} C & \mathcal{E} \end{bmatrix}}_{\tilde{C}} \tilde{x}(k)
\end{aligned}$$

with

$$\begin{aligned}
\tilde{A} &= \begin{bmatrix} \varepsilon & \varepsilon & \varepsilon & \varepsilon & \varepsilon & \varepsilon & \varepsilon & e & \varepsilon & \varepsilon & \varepsilon & \varepsilon \\ \varepsilon & \varepsilon & \varepsilon & \varepsilon & \varepsilon & \varepsilon & \varepsilon & 10 & \varepsilon & \varepsilon & \varepsilon & \varepsilon \\ \varepsilon & \varepsilon & \varepsilon & e & \varepsilon & \varepsilon & \varepsilon & \varepsilon & \varepsilon & \varepsilon & \varepsilon & \varepsilon \\ \varepsilon & \varepsilon & \varepsilon & 4 & \varepsilon & \varepsilon & \varepsilon & \varepsilon & \varepsilon & \varepsilon & \varepsilon & \varepsilon \\ \varepsilon & \varepsilon & \varepsilon & 5 & \varepsilon & e & \varepsilon & 11 & \varepsilon & \varepsilon & \varepsilon & \varepsilon \\ \varepsilon & \varepsilon & \varepsilon & 8 & \varepsilon & 3 & \varepsilon & 14 & \varepsilon & \varepsilon & \varepsilon & \varepsilon \\ e & \varepsilon & \varepsilon & \varepsilon & \varepsilon & \varepsilon & \varepsilon & \varepsilon & \varepsilon & \varepsilon & \varepsilon & \varepsilon \\ \varepsilon & e & \varepsilon & \varepsilon & \varepsilon & \varepsilon & \varepsilon & \varepsilon & \varepsilon & \varepsilon & \varepsilon & \varepsilon \\ \varepsilon & \varepsilon & e & \varepsilon & \varepsilon & \varepsilon & \varepsilon & \varepsilon & \varepsilon & \varepsilon & \varepsilon & \varepsilon \\ \varepsilon & \varepsilon & \varepsilon & e & \varepsilon & \varepsilon & \varepsilon & \varepsilon & \varepsilon & \varepsilon & \varepsilon & \varepsilon \\ \varepsilon & \varepsilon & \varepsilon & \varepsilon & e & \varepsilon & \varepsilon & \varepsilon & \varepsilon & \varepsilon & \varepsilon & \varepsilon \\ \varepsilon & \varepsilon & \varepsilon & \varepsilon & \varepsilon & e & \varepsilon & \varepsilon & \varepsilon & \varepsilon & \varepsilon & \varepsilon \end{bmatrix}, \quad \tilde{B} = \begin{bmatrix} e & \varepsilon & \varepsilon \\ 10 & \varepsilon & \varepsilon \\ \varepsilon & e & \varepsilon \\ \varepsilon & 4 & \varepsilon \\ 11 & 5 & e \\ 14 & 8 & 3 \\ \varepsilon & \varepsilon & \varepsilon \\ \varepsilon & \varepsilon & \varepsilon \\ \varepsilon & \varepsilon & \varepsilon \\ \varepsilon & \varepsilon & \varepsilon \\ \varepsilon & \varepsilon & \varepsilon \end{bmatrix}, \\
\tilde{C} &= [\varepsilon \ \varepsilon \ \varepsilon \ \varepsilon \ \varepsilon \ \varepsilon \ \varepsilon \ \varepsilon \ \varepsilon \ \varepsilon \ \varepsilon \ \varepsilon].
\end{aligned}$$

Remark 24 In general, the firing times of transition t_j in a TEG can be determined in max-plus algebra by

$$t_j(k) = \bigoplus_{p_i \in \bullet t_j} v_i \otimes t_{(\bullet p_i)}(k - m_i^0),$$

where $t_{(\bullet p_i)}(k)$ is the time instant that the input transition of p_i fires for the k^{th} time, i.e., $t_r(k)$ with $t_r \in \bullet p_i$.

Generally, it is possible to convert any timed event graph (as defined in this chapter) into a linear system in max-plus algebra. In such a max-plus algebraic system the variable $x_i(k)$ refers to the earliest possible time instant that transition x_i fires for the k^{th} time. Therefore, $\mathbf{x}(k)$ is also called dater function, as it determines a specific time (or date) for the firing of all transitions in the TEG. Another possible way to describe timed event graphs is through so called counter functions denoted $\mathbf{x}(t)$. These counter function determine the maximal number of firings of transitions up to time t , i.e., $x_i(t)$ refers to the maximal number of firings of transition x_i up to time t . Converting a timed event graph into a linear system of counter functions implies modeling the TEG as a min-plus linear system [2].

Example 17 (Timed event graphs and min-plus algebra) *To obtain a linear min-plus algebraic model of the TEG of our manufacturing example shown in Fig. 1.4, we have to determine the maximal number of firings of each transition. At time t transition x_1 can fire two times more often than transition x_2 has fired at time t (there are two tokens in place p_5 which has a holding time of 0) and as often as u_1 has fired at time t . Formally, this can be written in $(\overline{\mathbb{Z}}_{\min}, \oplus, \otimes)$*

$$x_1(t) = 2x_2(t) \oplus u_1(t).$$

Transition x_2 can fire at time t at most as often as transition x_1 has fired at time $t - 10$ (there are zero tokens in place p_4 which has a holding time of 10 time units). Thus, we get

$$x_2(t) = x_1(t - 10).$$

Similarly, we get for all other transitions

$$\begin{aligned} x_3(t) &= 1x_4(t) \oplus u_2(t) \\ x_4(t) &= x_3(t - 4) \\ x_5(t) &= x_2(t - 1) \oplus x_4(t - 1) \oplus 1x_6(t) \oplus u_3(t) \\ x_6(t) &= x_5(t - 3) \\ y(t) &= x_6(t) \end{aligned}$$

In matrix-vector form with $\mathbf{x}(t) = [x_1(t) x_2(t) x_3(t) x_4(t) x_5(t) x_6(t)]^T$ and $\mathbf{u}(t) = [u_1(t) u_2(t) u_3(t)]^T$ this yields

$$\begin{aligned} \mathbf{x}(t) &= \mathbf{A}_0\mathbf{x}(t) \oplus \mathbf{A}_1\mathbf{x}(t-1) \oplus \mathbf{A}_3\mathbf{x}(t-3) \oplus \dots \\ &\quad \dots \oplus \mathbf{A}_4\mathbf{x}(t-4) \oplus \mathbf{A}_{10}\mathbf{x}(t-10) \oplus \mathbf{B}\mathbf{u}(t) \end{aligned} \quad (1.42)$$

$$\mathbf{y}(t) = \mathbf{C}\mathbf{x}(t). \quad (1.43)$$

Using the Kleene star in min-plus algebra, this can be rewritten in explicit form, i.e.,

$$\begin{aligned} \mathbf{x}(t) &= \mathbf{A}_0^*(\mathbf{A}_1\mathbf{x}(t-1) \oplus \mathbf{A}_3\mathbf{x}(t-3) \oplus \mathbf{A}_4\mathbf{x}(t-4) \oplus \mathbf{A}_{10}\mathbf{x}(t-10) \oplus \mathbf{B}\mathbf{u}(t)) \\ \mathbf{y}(t) &= \mathbf{C}\mathbf{x}(t), \end{aligned}$$

and, as in the max-plus case, a first order recurrence relation $\tilde{\mathbf{x}}(t) = \tilde{\mathbf{A}}\tilde{\mathbf{x}}(t-1) \oplus \tilde{\mathbf{B}}\mathbf{u}(t), \mathbf{y}(t) = \tilde{\mathbf{C}}\tilde{\mathbf{x}}(t)$ can be obtained by suitably augmenting the vector $\mathbf{x}(t)$. However, for this specific system a possible augmented vector is $\tilde{\mathbf{x}}(t) = [\mathbf{x}(t)^T \mathbf{x}(t-1)^T \mathbf{x}(t-2)^T \dots \mathbf{x}(t-8)^T \mathbf{x}(t-9)^T]^T \in \overline{\mathbb{Z}}_{\min}^{60}$, which is a significant dimensional increase. Consequently, the corresponding matrix $\tilde{\mathbf{A}}$ would be a 60×60 matrix with entries in $\overline{\mathbb{Z}}_{\min}$, $\tilde{\mathbf{B}}$ would be a 60×3 matrix and $\tilde{\mathbf{C}}$ would be 1×60 .

Obviously, modeling a TEG as given in Fig. 1.4 as a first order recurrence relation in min-plus algebra is not convenient. Modeling the system as a first order recurrence relation in max-plus algebra may also not be convenient. It may then be preferable, to use other idempotent semirings such as the dioids $\overline{\mathbb{Z}}_{\max}[\gamma]$ or $\overline{\mathbb{Z}}_{\min}[\delta]$ to provide an algebraic relation. The system equation in the dioids $\overline{\mathbb{Z}}_{\max}[\gamma]$ or $\overline{\mathbb{Z}}_{\min}[\delta]$ can be achieved by applying the γ -transform (see Def. 27) or δ -transform (see Def. 29), respectively.

Example 18 (Timed event graphs and the dioid $\overline{\mathbb{Z}}_{\max}[\gamma]$) To obtain a linear algebraic relation in $\overline{\mathbb{Z}}_{\max}[\gamma]$ representing the dynamical behavior of the TEG displayed in Fig. 1.4, the γ -transform is applied to (1.40). This results in

$$\begin{aligned} \mathbf{x}(\gamma) &= \mathbf{A}_0\mathbf{x}(\gamma) \mathbf{A}_1\gamma\mathbf{x}(\gamma) \oplus \mathbf{A}_2\gamma^2\mathbf{x}(\gamma) \oplus \mathbf{B}\mathbf{u}(\gamma) \\ &= \underbrace{(\mathbf{A}_0 \oplus \gamma\mathbf{A}_1 \oplus \gamma^2\mathbf{A}_2)}_{\mathbf{A}(\gamma)} \mathbf{x}(\gamma) \oplus \mathbf{B}\mathbf{u}(\gamma) \\ &= \begin{bmatrix} \varepsilon & \gamma^2 & \varepsilon & \varepsilon & \varepsilon & \varepsilon \\ 10 & \varepsilon & \varepsilon & \varepsilon & \varepsilon & \varepsilon \\ \varepsilon & \varepsilon & \varepsilon & \gamma & \varepsilon & \varepsilon \\ \varepsilon & \varepsilon & 4 & \varepsilon & \varepsilon & \varepsilon \\ \varepsilon & 1 & \varepsilon & 1 & \varepsilon & \gamma \\ \varepsilon & \varepsilon & \varepsilon & \varepsilon & 3 & \varepsilon \end{bmatrix} \mathbf{x}(\gamma) \oplus \begin{bmatrix} e & \varepsilon & \varepsilon \\ \varepsilon & \varepsilon & \varepsilon \\ \varepsilon & e & \varepsilon \\ \varepsilon & \varepsilon & \varepsilon \\ \varepsilon & \varepsilon & e \\ \varepsilon & \varepsilon & \varepsilon \end{bmatrix} \mathbf{u}(\gamma) \\ \mathbf{y}(\gamma) &= \mathbf{C}\mathbf{x}(\gamma) \\ &= [\varepsilon \ \varepsilon \ \varepsilon \ \varepsilon \ \varepsilon \ e] \mathbf{x}(\gamma). \end{aligned}$$

Example 19 (Timed event graphs and dioid $\overline{\mathbb{Z}}_{\min}[\delta]$) Applying the δ -transform to (1.42) one obtains a linear algebraic system in $\overline{\mathbb{Z}}_{\min}[\delta]$ representing the dynamical behavior of the TEG shown in Fig. 1.4, i.e.,

$$\begin{aligned}
\mathbf{x}(\delta) &= \mathbf{A}_0 \mathbf{x}(\delta) \oplus \mathbf{A}_1 \delta \mathbf{x}(\delta) \oplus \mathbf{A}_3 \delta^3 \mathbf{x}(\delta) \oplus \mathbf{A}_4 \delta^4 \mathbf{x}(\delta) \oplus \mathbf{A}_{10} \delta^{10} \mathbf{x}(\delta) \oplus \mathbf{B} \mathbf{u}(\delta) \\
&= \underbrace{(\mathbf{A}_0 \oplus \delta \mathbf{A}_1 \oplus \delta^3 \mathbf{A}_3 \oplus \delta^4 \mathbf{A}_4 \oplus \delta^{10} \mathbf{A}_{10})}_{\mathbf{A}(\delta)} \mathbf{x}(\delta) \oplus \mathbf{B} \mathbf{u}(\delta) \\
&= \begin{bmatrix} \varepsilon & 2 & \varepsilon & \varepsilon & \varepsilon & \varepsilon \\ \delta^{10} & \varepsilon & \varepsilon & \varepsilon & \varepsilon & \varepsilon \\ \varepsilon & \varepsilon & \varepsilon & 1 & \varepsilon & \varepsilon \\ \varepsilon & \varepsilon & \delta^4 & \varepsilon & \varepsilon & \varepsilon \\ \varepsilon & \delta & \varepsilon & \delta & \varepsilon & 1 \\ \varepsilon & \varepsilon & \varepsilon & \varepsilon & \delta^3 & \varepsilon \end{bmatrix} \mathbf{x}(\delta) \oplus \begin{bmatrix} e & \varepsilon & \varepsilon \\ \varepsilon & \varepsilon & \varepsilon \\ \varepsilon & e & \varepsilon \\ \varepsilon & \varepsilon & \varepsilon \\ \varepsilon & \varepsilon & e \\ \varepsilon & \varepsilon & \varepsilon \end{bmatrix} \mathbf{u}(\delta) \\
\mathbf{y}(\delta) &= \mathbf{C} \mathbf{x}(\delta) \\
&= [\varepsilon \ \varepsilon \ \varepsilon \ \varepsilon \ \varepsilon \ e] \mathbf{x}(\delta).
\end{aligned}$$

Comparing the linear representations in the dioids $\overline{\mathbb{Z}}_{\max}[\gamma]$ and $\overline{\mathbb{Z}}_{\min}[\delta]$ of the TEG shown in Fig. 1.4, it is easy to recognize their correlation. While the coefficients of the elements in matrix $\mathbf{A}(\gamma)$ in $\overline{\mathbb{Z}}_{\max}[\gamma]$ represent the holding times and the exponents of γ represent the number of tokens in the corresponding places, it is reversed in matrix $\mathbf{A}(\delta)$ in $\overline{\mathbb{Z}}_{\min}[\delta]$. However, it is important to note, that the definitions of \oplus and \otimes differ in $\overline{\mathbb{Z}}_{\max}[\gamma]$ from the definitions of these operations in $\overline{\mathbb{Z}}_{\min}[\delta]$.

To put it in a nutshell, it is possible to model the dynamic behavior of a timed event graph as a max-plus linear system as well as a min-plus linear system. It is also possible to achieve linear algebraic models of TEG in the dioids $\overline{\mathbb{Z}}_{\max}[\gamma]$ and $\overline{\mathbb{Z}}_{\min}[\delta]$. Which dioid is used to model the dynamic behavior of a specific TEG depends on the system to be modeled itself but also on the biases of the user who wants to describe the system. The first issue becomes clear, when we consider a system which works with a specific sampling time. In this case a model in min-plus algebra or in $\overline{\mathbb{Z}}_{\min}[\delta]$ may be very convenient, since the occurrence of events, i.e., the firing of transitions, can be recognized at every sampling step. For event driven systems, however, a model in max-plus algebra or $\overline{\mathbb{Z}}_{\max}[\gamma]$ may fit better than a system in min-plus algebra.

Nonetheless, in our opinion, the most convenient idempotent semiring to model (almost) any TEG in an efficient way is the dioid $\mathcal{M}_{in}^{ax}[\gamma, \delta]$ (see Def. 33), which is a two dimensional dioid in γ and δ with Boolean coefficients and integer exponents. $\mathcal{M}_{in}^{ax}[\gamma, \delta]$ can be seen as a combination of the dioid $\overline{\mathbb{Z}}_{\max}[\gamma]$ and $\overline{\mathbb{Z}}_{\min}[\delta]$. Models in $\mathcal{M}_{in}^{ax}[\gamma, \delta]$ are equally suitable for systems with a fixed sampling time and event driven systems. Therefore, in the remainder of this chapter timed event graphs will be described in the idempotent semiring $\mathcal{M}_{in}^{ax}[\gamma, \delta]$. Consequently, all dioid operations and system descriptions are meant to be in $\mathcal{M}_{in}^{ax}[\gamma, \delta]$ unless stated otherwise.

Example 20 (Timed event graphs and the dioid $\mathcal{M}_{in}^{ax}[\gamma, \delta]$) *The linear representation of the TEG given in Fig. 1.4 in the dioid $\mathcal{M}_{in}^{ax}[\gamma, \delta]$ is*

$$\begin{aligned}
\mathbf{x}(\gamma, \delta) &= \mathbf{A}(\gamma, \delta)\mathbf{x}(\gamma, \delta) \oplus \mathbf{B}\mathbf{u}(\gamma, \delta) \\
&= \begin{bmatrix} \varepsilon & \gamma^2 & \varepsilon & \varepsilon & \varepsilon & \varepsilon \\ \delta^{10} & \varepsilon & \varepsilon & \varepsilon & \varepsilon & \varepsilon \\ \varepsilon & \varepsilon & \varepsilon & \gamma & \varepsilon & \varepsilon \\ \varepsilon & \varepsilon & \delta^4 & \varepsilon & \varepsilon & \varepsilon \\ \varepsilon & \delta & \varepsilon & \delta & \varepsilon & \gamma \\ \varepsilon & \varepsilon & \varepsilon & \varepsilon & \delta^3 & \varepsilon \end{bmatrix} \mathbf{x}(\gamma, \delta) \oplus \begin{bmatrix} e & \varepsilon & \varepsilon \\ \varepsilon & \varepsilon & \varepsilon \\ \varepsilon & e & \varepsilon \\ \varepsilon & \varepsilon & \varepsilon \\ \varepsilon & \varepsilon & e \\ \varepsilon & \varepsilon & \varepsilon \end{bmatrix} \mathbf{u}(\gamma, \delta) \\
\mathbf{y}(\gamma, \delta) &= \mathbf{C}\mathbf{x}(\gamma, \delta) \\
&= [\varepsilon \ \varepsilon \ \varepsilon \ \varepsilon \ \varepsilon \ e] \mathbf{x}(\gamma, \delta).
\end{aligned}$$

Remark 25 (Software) *There are several software packages available to handle linear system in a dioid settings, e.g., the max-plus algebra toolbox for ScicosLab www.scicoslab.org, or the C++ library MinMaxGD to manipulate periodic series in $\mathcal{M}_{in}^{ax}[\gamma, \delta]$ [11].*

1.5 Modeling Manufacturing Systems with Dioids

1.5.1 Input-output behavior of manufacturing systems

In the previous sections, it has been shown, how certain manufacturing systems can be modeled as a timed event graph and how this TEG can then be transformed into a linear system in $\mathcal{M}_{in}^{ax}[\gamma, \delta]$. The obtained system has a structure that is well known from linear system theory, i.e.,

$$\begin{aligned}
\mathbf{x} &= \mathbf{A}\mathbf{x} \oplus \mathbf{B}\mathbf{u} \\
\mathbf{y} &= \mathbf{C}\mathbf{x}.
\end{aligned}$$

As $\mathcal{M}_{in}^{ax}[\gamma, \delta]$ is a complete dioid, using the Kleene star, this system can be rewritten

$$\begin{aligned}
\mathbf{x} &= \mathbf{A}\mathbf{x} \oplus \mathbf{B}\mathbf{u} \\
&= \mathbf{A}^*\mathbf{B}\mathbf{u} \\
\mathbf{y} &= \mathbf{C}\mathbf{x}
\end{aligned}$$

and replacing \mathbf{x} in the output equation one obtains

$$\mathbf{y} = \mathbf{C}\mathbf{A}^*\mathbf{B}\mathbf{u}.$$

The resulting matrix $\mathbf{H} = \mathbf{C}\mathbf{A}^*\mathbf{B}$ is called transfer matrix (or transfer relation) of the system as it represents its input-output relation.

Example 21 (Simple manufacturing system (cont.)) *The input-output behavior of our running example (see Fig. 1.4) can easily be determined using appropriate soft-*

ware packages (see Rem. 25). To do so, one first has to compute the Kleene star of system matrix \mathbf{A} ,

$$\mathbf{A}^* = \begin{bmatrix} (\gamma^2 \delta^{10})^* & \gamma^2 (\gamma^2 \delta^{10})^* & \varepsilon & \varepsilon & \varepsilon & \varepsilon \\ \delta^{10} (\gamma^2 \delta^{10})^* & (\gamma^2 \delta^{10})^* & \varepsilon & \varepsilon & \varepsilon & \varepsilon \\ \varepsilon & \varepsilon & (\gamma \delta^4)^* & \gamma (\gamma \delta^4)^* & \varepsilon & \varepsilon \\ \varepsilon & \varepsilon & \delta^4 (\gamma \delta^4)^* & (\gamma \delta^4)^* & \varepsilon & \varepsilon \\ (\delta^{11} \oplus \gamma \delta^{14}) (\gamma^2 \delta^{10})^* & (\delta \oplus \gamma \delta^4) (\gamma^2 \delta^{10})^* & \delta^5 (\gamma \delta^4)^* & \delta (\gamma \delta^4)^* & (\gamma \delta^3)^* & \gamma (\gamma \delta^3)^* \\ (\delta^{14} \oplus \gamma \delta^{17}) (\gamma^2 \delta^{10})^* & (\delta^4 \oplus \gamma \delta^7) (\gamma^2 \delta^{10})^* & \delta^8 (\gamma \delta^4)^* & \delta^4 (\gamma \delta^4)^* & \delta^3 (\gamma \delta^3)^* & (\gamma \delta^3)^* \end{bmatrix}.$$

Taking a look at matrix \mathbf{A}^* , the general structure of the modeled system can be recognized. The top left (2×2) -block represents resource R_A , the next (2×2) -block on the diagonal represents resource R_B . Both are independent of the operation of other resources. Resource 3, which is represented by the bottom-right (2×2) -block, depends on the operation of both resources R_A and R_B , and therefore, the bottom-left (2×4) -block is non-zero. Furthermore, it can be seen, that the resources have different throughputs. While resource R_A can process up to 2 parts every 10 time units, resource R_B can process 1 part every 4 time units. The fastest machine is resource R_C with up to 1 part every 3 time units, however, as mentioned before, this resource is constrained by the operation of R_A and R_B and consequently, its throughput is constrained by the throughput of R_A and R_B as well. This specific structure is also visible in matrix $\mathbf{A}^* \mathbf{B}$

$$\begin{aligned} \mathbf{x} &= \mathbf{A}^* \mathbf{B} \mathbf{u} \\ &= \begin{bmatrix} (\gamma^2 \delta^{10})^* & \varepsilon & \varepsilon \\ \delta^{10} (\gamma^2 \delta^{10})^* & \varepsilon & \varepsilon \\ \varepsilon & (\gamma \delta^4)^* & \varepsilon \\ \varepsilon & \delta^4 (\gamma \delta^4)^* & \varepsilon \\ (\delta^{11} \oplus \gamma \delta^{14}) (\gamma^2 \delta^{10})^* & \delta^5 (\gamma \delta^4)^* & (\gamma \delta^3)^* \\ (\delta^{14} \oplus \gamma \delta^{17}) (\gamma^2 \delta^{10})^* & \delta^8 (\gamma \delta^4)^* & \delta^3 (\gamma \delta^3)^* \end{bmatrix} \mathbf{u}. \end{aligned}$$

Finally, the transfer relation of this system is

$$\begin{aligned} \mathbf{y} &= \mathbf{C} \mathbf{A}^* \mathbf{B} \mathbf{u} \\ &= [(\delta^{14} \oplus \gamma \delta^{17}) (\gamma^2 \delta^{10})^* \delta^8 (\gamma \delta^4)^* \delta^3 (\gamma \delta^3)^*] \mathbf{u}. \end{aligned}$$

Now, given a specific input vector \mathbf{u} it is possible to determine the time instants that the final products (part C) are assembled and released from the system. Assuming for example, that unlimited raw parts are available at any time, i.e., $u_i = e$. Recall that the unit element in $\mathcal{M}_{in}^{ax}[\gamma, \delta]$ represents an equivalence class, i.e., $e = \gamma^0 \delta^0 = \gamma^0 \delta^0 \oplus \gamma^1 \delta^0 \oplus \gamma^2 \delta^0 \oplus \dots$. This basically means, that the input transitions fire infinitely often at time 0 and, therefore, do not constrain the manufacturing system. Consequently, considering the input $u_i = e$ for all inputs results in the fastest possible output. For our example, we get

$$\begin{aligned} \mathbf{y} &= [(\delta^{14} \oplus \gamma \delta^{17}) (\gamma^2 \delta^{10})^* \delta^8 (\gamma \delta^4)^* \delta^3 (\gamma \delta^3)^*] \mathbf{e} \\ &= (\delta^{14} \oplus \gamma \delta^{17}) (\gamma^2 \delta^{10})^*. \end{aligned}$$

Thus, the first part is finished (at the earliest) at time $t = 14$, the second part can be finished at time $t = 17$, the third part at time $t = 24$, the fourth part at time $t = 27$ and so on. The overall throughput of the system is 2 parts every 10 time units, which represents the throughput of resource R_A . Accordingly, resource R_A is the bottleneck of the system, i.e., the slowest resource. If the user wants to speed up the system, he or she has to increase the throughput of resource R_A first, e.g., by increasing the capacity of the resource.

Of course, it is also (easily) possible to determine the state evolution of the system in case of an unconstraining input, i.e.,

$$\begin{aligned} \mathbf{x} &= \mathbf{A}^* \mathbf{B} \mathbf{e} \\ &= \begin{bmatrix} (\gamma^2 \delta^{10})^* \\ \delta^{10} (\gamma^2 \delta^{10})^* \\ (\gamma \delta^4)^* \\ \delta^4 (\gamma \delta^4)^* \\ (\delta^{11} \oplus \gamma \delta^{14}) (\gamma^2 \delta^{10})^* \\ (\delta^{14} \oplus \gamma \delta^{17}) (\gamma^2 \delta^{10})^* \end{bmatrix}. \end{aligned}$$

This state evolution reveals that resource R_A has a throughput of 2 parts every 10 time units, resource R_B has a throughput of 1 part every 4 time units, and resource R_C , which has an internal throughput of 1 part every 3 time units, “inherits” the smaller throughput of resource R_A , which has to provide parts for resource R_C .

Remark 26 (Control theory for linear systems in a dioid setting) *The state evolution determined in Ex. 21 includes different throughputs for the different resources. In particular, resource R_B is working faster than the other two resources. As a consequence, there will be an accumulation of parts B, which have to wait to be further processed by resource R_C . In terms of timed event graphs, there will be an accumulation of tokens in the place between x_4 and x_5 . For example, if all resources work as fast as possible, i.e., all transitions fire as early as possible, at time $t=100$ there will be 7 parts B waiting for processing by R_C (25 parts B have been finished, and the processing of 18 parts C has been started), at time $t=1000$ the number of parts B waiting between resource R_B and R_C adds up to 52 (250 parts B have been released but only 198 of them have been further processed by R_C). This is certainly not desired as these parts B have to be stored until they are needed for the processing of part C. To avoid this and to reduce storing capacity, one often imposes a just-in-time policy, i.e., the production of intermediate parts is started such that these parts are finished just in time for subsequent processing steps. If the system should work at maximum speed, just-in-time means that every process should be started as late as possible without reducing the (fastest) throughput of the overall system. For Ex. 21 the just-in-time input, i.e., the largest \mathbf{u} with respect to the order relation of $\mathcal{M}_{in}^{ax}[\gamma, \delta]$ that does not delay the output, is relatively easy to determine, i.e.,*

$$\mathbf{u}_{jit} = \begin{bmatrix} (e \oplus \gamma \delta^3) (\gamma^2 \delta^{10})^* \\ (\delta^5 \oplus \gamma \delta^9) (\gamma^2 \delta^{10})^* \\ (\delta^{11} \oplus \gamma \delta^{14}) (\gamma^2 \delta^{10})^* \end{bmatrix}.$$

However, for more complex systems, the optimal input with respect to the just-in-time policy may not be as obvious. Furthermore, it is desirable to determine u_{jit} in a feedback fashion to allow it to react to possible unforeseen delays that may occur during the operation of the manufacturing system. To solve these issues, residuation theory (see Def. 17) can be employed. Using residuation theory, one can easily compute the optimal just-in-time input for a given output. Moreover, on the basis of residuation, an extensive control theory, including input filtering, state feedback control, output control, disturbance decoupling, and model predictive control has been developed. For more information on the control theory in dioids, the interested reader is referred to the numerous publications in this field, e.g., [9, 10, 12, 15, 16, 19, 21, 22, 28].

Timed event graphs and their linear representation in dioids are suitable tools for the efficient modeling of certain manufacturing systems subject to delay and synchronization phenomena. However, some systems may exhibit specific features that cannot be readily included in a standard TEG model. For example, the processing of a part on a resource may have to be performed within a time interval, also called time window. Thus, with respect to TEG, there exists not only a minimal time a token has to spend in a place but also an upper bound for the time, by which the token has to be removed from the place by its output transition. Similarly, while it is possible to model the maximal number of tokens in a part of the TEG, e.g., the maximal number of parts being processed at the same time in a resource, it is not possible to model a minimal number of tokens that have to be present in this part of the TEG. Such properties arise naturally if one requires the input transitions of certain places to fire a specific number of times more often than the corresponding output transitions. Constraints on the minimal number of tokens frequently occur, for example, in resource allocation problems which are quite common in manufacturing system. They are also common in high-throughput screening (HTS), which has become an important technology to rapidly test thousands of bio-chemical substances [14, 27] and is mostly used in pharmaceutical industries for a first screening in the process of drug discovery.

While the issue of timed event graphs with time window constraints or similar temporal constraints has been handled in several publications, e.g., [1, 18, 20, 23], the latter issue concerning a minimal number of tokens in a place has, to our knowledge, not yet been addressed. In the following, we will show one possible way to include time window constraints as well as constraints on the minimal number of tokens in timed event graphs and their corresponding linear representation in dioids.

1.5.2 Modeling time window constraints

Example 22 (Manufacturing systems with time window constraints) *Consider a (part of a) manufacturing system which, similar to the system in Ex. 21, combines two intermediate products to a final product. However, once intermediate product 1 has been finished it has to rest for at least 3 but not more than 5 time units be-*

fore it can be further processed. Similarly, intermediate product 2 has to rest for at least 1 but not more than 4 time units after it has been finished. Thus, there are time windows for the resting periods of both intermediate products. The corresponding part of the timed event graph is given in Fig. 1.11. In this figure, the brackets at the places represent the time window with its lower and upper bound. For this TEG it is

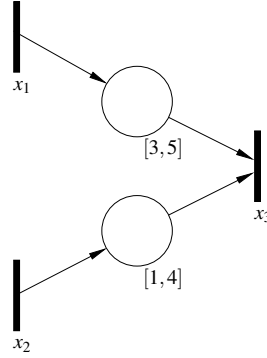

Fig. 1.11 Part of a timed event graph with time window constraints.

quite simple to determine the dependencies in $\mathcal{M}_{in}^{ax}[\gamma, \delta]$. The lower bounds of the time window are modeled as for standard TEG, i.e.,

$$\begin{aligned} x_3 &\succeq \delta^3 x_1 \\ x_3 &\succeq \delta x_2. \end{aligned}$$

This means that x_3 can fire as soon as 3 time units have passed after the firing of x_1 and 1 time unit needs to have passed after the firing of x_2 . Consequently the two dependencies can be merged to

$$x_3 \succeq \delta^3 x_1 \oplus \delta x_2. \quad (1.44)$$

The upper bounds of the time window are modeled similarly. Transition x_3 has to fire at the latest 5 time units after the firing of x_1 and not later than 4 time units after the firing of x_2 . In $\mathcal{M}_{in}^{ax}[\gamma, \delta]$ this can be written

$$\begin{aligned} x_3 &\preceq \delta^5 x_1 \\ x_3 &\preceq \delta^4 x_2. \end{aligned}$$

These two constraints can be merged to

$$x_3 \preceq \delta^5 x_1 \wedge \delta^4 x_2. \quad (1.45)$$

Note that the dependencies of the lower bounds are merged by \oplus into their greatest lower bounds, and the upper bounds are merged into their least upper bound. Equations (1.44) and (1.45) can be written in matrix vector form

$$\mathbf{x} \preceq \begin{bmatrix} \varepsilon & \varepsilon & \varepsilon \\ \varepsilon & \varepsilon & \varepsilon \\ \delta^3 & \delta & \varepsilon \end{bmatrix} \otimes \mathbf{x} \quad (1.46)$$

$$\mathbf{x} \preceq \begin{bmatrix} \top & \top & \top \\ \top & \top & \top \\ \delta^5 & \delta^4 & \top \end{bmatrix} \odot \mathbf{x}. \quad (1.47)$$

It is important to note that the dependencies of the upper time window constraints are written in terms of the dual multiplication (see Def. 21 for details) and that the zero element of this operation is \top .

In the previous example there are two different kinds of constraints on the system and it is not ad hoc possible to determine a linear model in $\mathcal{M}_{in}^{ax}[\gamma, \delta]$. In the following we will show how (under some conditions) such a linear model can be achieved. Our approach is based on the method introduced in [24, 25, 23].

Formally, the internal behavior of the system is defined by two types of constraints, i.e.,

$$\mathbf{x} \preceq \underline{\mathbf{A}} \otimes \mathbf{x} \quad (1.48)$$

$$\mathbf{x} \preceq \overline{\mathbf{A}} \odot \mathbf{x} \quad (1.49)$$

where the entries of $\underline{\mathbf{A}}$ represent the lower time bounds imposed by a standard timed event graph and the entries of $\overline{\mathbf{A}}$ represent the upper bounds of the time windows and the minimal number of tokens between two transitions. According to Lemma 1 and 5, any solution of the above inequalities also satisfies

$$\mathbf{x} = \underline{\mathbf{A}}^* \otimes \mathbf{x}$$

$$\mathbf{x} = \overline{\mathbf{A}}_* \odot \mathbf{x}.$$

The aim is to find an \mathbf{x} that fulfills both constraints, which means that we have to guarantee that \mathbf{x} is in the image of $L_{\underline{\mathbf{A}}^*}$ and in the image of $\Lambda_{\overline{\mathbf{A}}_*}$ (see Rem. 11 and Rem. 13). Formally,

$$\underline{\mathbf{A}}^* \otimes \mathbf{x} = \mathbf{x} = \overline{\mathbf{A}}_* \odot \mathbf{x} \Leftrightarrow \mathbf{x} \in \text{Im}L_{\underline{\mathbf{A}}^*} \cap \text{Im}\Lambda_{\overline{\mathbf{A}}_*}. \quad (1.50)$$

It can be shown [5] that, if every entry of $\overline{\mathbf{A}}_*$ is either ε , \top or admits a multiplicative inverse, the map $P : \mathbf{x} \mapsto (\overline{\mathbf{A}}_* \bullet \underline{\mathbf{A}}^*)^* \circlearrowleft \mathbf{x}$ is a projector in $\text{Im}L_{\underline{\mathbf{A}}^*} \cap \text{Im}\Lambda_{\overline{\mathbf{A}}_*}$. Hence, if this condition holds, $\mathbf{x} \in \text{Im}L_{\underline{\mathbf{A}}^*} \cap \text{Im}\Lambda_{\overline{\mathbf{A}}_*}$ is equivalent to $\mathbf{x} = (\overline{\mathbf{A}}_* \bullet \underline{\mathbf{A}}^*)^* \circlearrowleft \mathbf{x}$. This, according to Lemma 1, is equivalent to

$$\mathbf{x} = \underbrace{(\overline{\mathbf{A}}_* \bullet \mathbf{A}^*)^*}_{\overline{\mathbf{A}}^*} \otimes \mathbf{x}.$$

Consequently, if the invertibility condition for the entries of $\overline{\mathbf{A}}_*$ holds, the matrix $\overline{\mathbf{A}}^*$ captures the constraints (1.48) and (1.49) and therefore represents time window constraints.

Example 23 (Simple manufacturing system with time window constraints) *Re-consider the simple manufacturing system of Ex. 21 with an additional time window constraint between transition x_4 and x_5 , such that x_5 has to fire at the latest 2 time units after x_4 has fired. The corresponding (extended) TEG is given in Fig. 1.12. As*

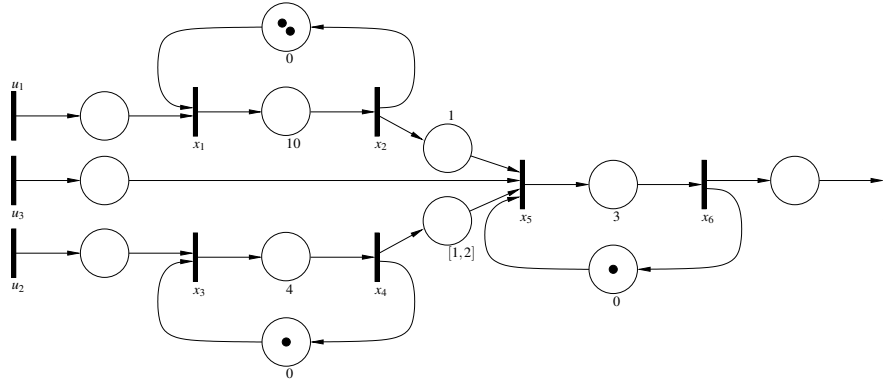

Fig. 1.12 Simple manufacturing system with time window constraints.

nothing has changed except for the upper bound for the time between the firing of x_4 and x_5 the matrix \mathbf{A}^* given in Ex. 21 is equivalent to matrix $\underline{\mathbf{A}}^*$ of the system with time window constraints given in Fig. 1.12. The only additional constraint is

$$x_5 \preceq \delta^2 \odot x_4,$$

i.e., transition x_5 shall fire (for the k^{th} time) at the latest two time units after transition x_4 has fired for the k^{th} time. Consequently, matrix $\overline{\mathbf{A}}$ has a single entry not equal to \top , i.e., $[\overline{\mathbf{A}}]_{54} = \delta^2$. The resulting $\overline{\mathbf{A}}^*$ capturing all constraints is

$$\begin{aligned} \overline{\mathbf{A}}^* &= (\overline{\mathbf{A}}_* \bullet \mathbf{A}^*)^* \\ &= \begin{bmatrix} (\gamma^2 \delta^{10})^* & \gamma^2 (\gamma^2 \delta^{10})^* & \varepsilon & \varepsilon & \varepsilon & \varepsilon \\ \delta^{10} (\gamma^2 \delta^{10})^* & (\gamma^2 \delta^{10})^* & \varepsilon & \varepsilon & \varepsilon & \varepsilon \\ (\gamma \delta^9 \oplus \gamma^2 \delta^{13}) (\gamma^2 \delta^{10})^* & (\gamma \delta^{-1} \oplus \gamma^2 \delta^3) (\gamma^2 \delta^{10})^* & (\gamma \delta^4)^* & \gamma (\gamma \delta^4)^* & (\gamma \delta^{-2}) (\gamma \delta^4)^* & (\gamma^2 \delta^{-2}) (\gamma \delta^4)^* \\ (\delta^9 \oplus \gamma \delta^{13}) (\gamma^2 \delta^{10})^* & (\delta^{-1} \oplus \gamma \delta^3) (\gamma^2 \delta^{10})^* & \delta^4 (\gamma \delta^4)^* & (\gamma \delta^4)^* & \delta^{-2} (\gamma \delta^4)^* & \gamma \delta^{-2} (\gamma \delta^4)^* \\ (\delta^{11} \oplus \gamma \delta^{14}) (\gamma^2 \delta^{10})^* & (\delta \oplus \gamma \delta^4) (\gamma^2 \delta^{10})^* & \delta^5 (\gamma \delta^4)^* & \delta (\gamma \delta^4)^* & \varepsilon \oplus (\gamma \delta^3) (\gamma \delta^4)^* & \gamma \oplus (\gamma^2 \delta^3) (\gamma \delta^4)^* \\ (\delta^{14} \oplus \gamma \delta^{17}) (\gamma^2 \delta^{10})^* & (\delta^4 \oplus \gamma \delta^7) (\gamma^2 \delta^{10})^* & \delta^8 (\gamma \delta^4)^* & \delta^4 (\gamma \delta^4)^* & \delta^3 \oplus (\gamma \delta^6) (\gamma \delta^4)^* & \varepsilon \oplus \gamma \delta^3 \oplus (\gamma^2 \delta^6) (\gamma \delta^4)^* \end{bmatrix}. \end{aligned}$$

Then the system state x can be computed by

$$\begin{aligned} x &= \overline{\mathbf{A}}^* \mathbf{B} \mathbf{u} \\ &= \begin{bmatrix} (\gamma^2 \delta^{10})^* & \varepsilon & \varepsilon \\ \delta^{10} (\gamma^2 \delta^{10})^* & \varepsilon & \varepsilon \\ (\gamma \delta^9 \oplus \gamma^2 \delta^{13}) (\gamma^2 \delta^{10})^* & (\gamma \delta^4)^* & \gamma \delta^{-2} (\gamma \delta^4)^* \\ (\delta^9 \oplus \gamma \delta^{13}) (\gamma^2 \delta^{10})^* & \delta^4 (\gamma \delta^4)^* & \delta^{-2} (\gamma \delta^4)^* \\ (\delta^{11} \oplus \gamma \delta^{14}) (\gamma^2 \delta^{10})^* & \delta^5 (\gamma \delta^4)^* & e \oplus (\gamma \delta^3) (\gamma \delta^4)^* \\ (\delta^{14} \oplus \gamma \delta^{17}) (\gamma^2 \delta^{10})^* & \delta^8 (\gamma \delta^4)^* & \delta^3 \oplus (\gamma \delta^6) (\gamma \delta^4)^* \end{bmatrix} \mathbf{u}, \end{aligned}$$

which is not causal with respect to Def. 34. The corresponding causal projection of the transfer relation is

$$\begin{aligned} x &= Pr_{caus}(\overline{\mathbf{A}}^* \mathbf{B}) \mathbf{u} \\ &= \begin{bmatrix} (\gamma^2 \delta^{10})^* & \varepsilon & \varepsilon \\ \delta^{10} (\gamma^2 \delta^{10})^* & \varepsilon & \varepsilon \\ (\gamma \delta^9 \oplus \gamma^2 \delta^{13}) (\gamma^2 \delta^{10})^* & (\gamma \delta^4)^* & \gamma^2 \delta^2 (\gamma \delta^4)^* \\ (\delta^9 \oplus \gamma \delta^{13}) (\gamma^2 \delta^{10})^* & \delta^4 (\gamma \delta^4)^* & \gamma \delta^2 (\gamma \delta^4)^* \\ (\delta^{11} \oplus \gamma \delta^{14}) (\gamma^2 \delta^{10})^* & \delta^5 (\gamma \delta^4)^* & e \oplus (\gamma \delta^3) (\gamma \delta^4)^* \\ (\delta^{14} \oplus \gamma \delta^{17}) (\gamma^2 \delta^{10})^* & \delta^8 (\gamma \delta^4)^* & \delta^3 \oplus (\gamma \delta^6) (\gamma \delta^4)^* \end{bmatrix} \mathbf{u}, \end{aligned}$$

and the earliest possible firing of all internal transitions is

$$\begin{aligned} x &= Pr_{caus}(\overline{\mathbf{A}}^* \mathbf{B}) \mathbf{e} \\ &= \begin{bmatrix} (\gamma^2 \delta^{10})^* \\ \delta^{10} (\gamma^2 \delta^{10})^* \\ (\gamma \delta^9 \oplus \gamma^2 \delta^{13}) (\gamma^2 \delta^{10})^* \\ (\delta^9 \oplus \gamma \delta^{13}) (\gamma^2 \delta^{10})^* \\ (\delta^{11} \oplus \gamma \delta^{14}) (\gamma^2 \delta^{10})^* \\ (\delta^{14} \oplus \gamma \delta^{17}) (\gamma^2 \delta^{10})^* \end{bmatrix}. \end{aligned}$$

Looking at the earliest possible firings of internal transitions, it becomes clear that the time window constraint affects the operation of resource R_B (represented by transitions x_3 and x_4). Since the start of processing part C may not be more than 2 time units after part B is finished, the production of B is slowed down to the production rate of resource R_C , which is constrained by the throughput of resource R_A , the bottleneck of the system. Consequently, the earliest possible and admissible firing of every transition has the same throughput of 2 parts every 10 time units. Furthermore, the transfer relation of the system also changes, i.e.,

$$\begin{aligned} y &= \mathbf{C} \overline{\mathbf{A}}^* \mathbf{B} \mathbf{u} \\ &= [(\delta^{14} \oplus \gamma \delta^{17}) (\gamma^2 \delta^{10})^* \ \delta^8 (\gamma \delta^4)^* \ \delta^3 \oplus (\gamma \delta^6) (\gamma \delta^4)^*] \mathbf{u} \end{aligned}$$

While the firing of internal transitions and the transfer relation change due to the additional time window constraint, the fastest throughput of the overall system remains the same, i.e.,

$$\begin{aligned} y &= \overline{CA^*} B e \\ &= (\delta^{14} \oplus \gamma \delta^{17}) (\gamma^2 \delta^{10})^* . \end{aligned}$$

This is due to the fact that the introduced time window does not affect the overall throughput of the system, but rather imposes an addition constraint on its internal behavior.

1.5.3 Modeling reentrant operations

The previous example described a system with time window constraints. In the following example, a system is described in which a minimal number of tokens is required in certain places, e.g., to increase the throughput of the system.

Example 24 (Nested schedules in manufacturing systems) Consider a simple manufacturing system which consists of a single resource with a capacity of 1. However, this resource has to perform two processing steps on every part. The minimal times for these two processing steps, also called activities, are 2 time units and 1 time unit, respectively. In between these two activities the part is moved to a buffer of appropriate size and has to rest there for at least 2 time units. Using this setup, parts should be produced in an efficient way. A rather naive approach would be to start producing one part after the other. The corresponding TEG of this approach is given in Fig. 1.13. In this figure, the input represents the provision with raw ma-

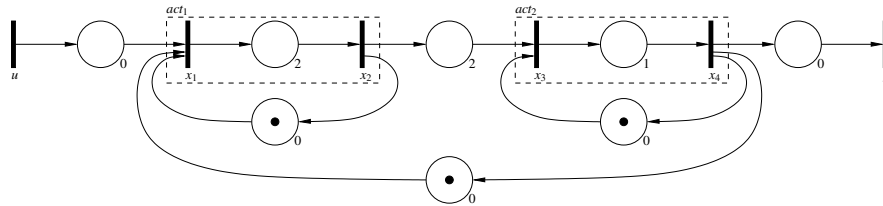

Fig. 1.13 TEG of the simple manufacturing system (Ex. 24).

terial, the output y refers to the finishing of a part and x_1 and x_2 (resp. x_3 and x_4) model the start and finish events of activity one (resp. activity two). The activities are indicated by dashed boxes and the buffer is represented by the place in between the two activities. The capacity of the single resource is modeled by the three initial tokens shown in Fig. 1.13. Since the resource has a single capacity, act_1 cannot start earlier than the same activity of the previous part has been finished. Likewise, act_2 cannot start until the preceding act_2 has been finished and act_1 can only start if the previous part has been finished processing in act_2 . In other words, at any time there is at most one part processed in act_1 , there is also at most one part processed in

act_2 , and finally, at any time there is at most one part processed in the system. In fact, modeling the “capacity” of an activity is not necessary in this setting, however, later on (in a different setting, i.e., in operations with nested schedules) this may be crucial for the correct modeling of the system’s behavior. The linear representation of the TEG given in Fig. 1.13 in $\mathcal{M}_{in}^{ax}[\gamma, \delta]$ results in

$$\mathbf{x} = \underbrace{\begin{bmatrix} \varepsilon & \gamma & \varepsilon & \gamma \\ \delta^2 & \varepsilon & \varepsilon & \varepsilon \\ \varepsilon & \delta^2 & \varepsilon & \gamma \\ \varepsilon & \varepsilon & \delta & \varepsilon \end{bmatrix}}_A \mathbf{x} \oplus \underbrace{\begin{bmatrix} e \\ \varepsilon \\ \varepsilon \\ \varepsilon \end{bmatrix}}_B u$$

$$y = \underbrace{[\varepsilon \ \varepsilon \ \varepsilon \ e]}_C \mathbf{x}.$$

The smallest solution of the implicit equation is

$$\begin{aligned} \mathbf{x} &= \mathbf{A}^* \mathbf{B} u \\ &= \begin{bmatrix} (\gamma\delta^5)^* & \gamma\delta^3(\gamma\delta^5)^* & \gamma\delta(\gamma\delta^5)^* & \gamma(\gamma\delta^5)^* \\ \delta^2(\gamma\delta^5)^* & (\gamma\delta^5)^* & \gamma\delta^3(\gamma\delta^5)^* & \gamma\delta^2(\gamma\delta^5)^* \\ \delta^4(\gamma\delta^5)^* & \delta^2(\gamma\delta^5)^* & (\gamma\delta^5)^* & \gamma\delta^4(\gamma\delta^5)^* \\ \delta^5(\gamma\delta^5)^* & \delta^3(\gamma\delta^5)^* & \delta(\gamma\delta^5)^* & (\gamma\delta^5)^* \end{bmatrix} \begin{bmatrix} e \\ \varepsilon \\ \varepsilon \\ \varepsilon \end{bmatrix} u \\ &= \begin{bmatrix} (\gamma\delta^5)^* \\ \delta^2(\gamma\delta^5)^* \\ \delta^4(\gamma\delta^5)^* \\ \delta^5(\gamma\delta^5)^* \end{bmatrix} u, \end{aligned}$$

and the corresponding input-output behavior of the system is

$$\begin{aligned} y &= \mathbf{C} \mathbf{x} = \mathbf{C} \mathbf{A}^* \mathbf{B} u \\ &= \delta^5 (\gamma\delta^5)^* u. \end{aligned}$$

Looking at the transfer relation one can easily see that 5 time units after the input has fired for the first time, the first part is finished. Furthermore, the maximal throughput of the system is 1 part every 5 time units. Often the operation of a manufacturing system is visualized by a so called Gantt chart. The Gantt chart of this example is given in Fig. 14(a). Looking at the Gantt chart of the example it is obvious, that the capacity utilization of the single resource R_1 is rather low. More precisely, between the execution of act_1 and act_2 of a part the resource is idle. To increase the efficiency of the manufacturing system, the user may want to try to reduce this idle time by choosing a different schedule. For example, the idle time of the resource when producing part k may be used to execute act_1 of the next part, i.e., part $k+1$, and consequently act_2 of part k will be executed between act_1 and act_2 of part $k+1$. Such a schedule is said to be nested as (at least) one activity

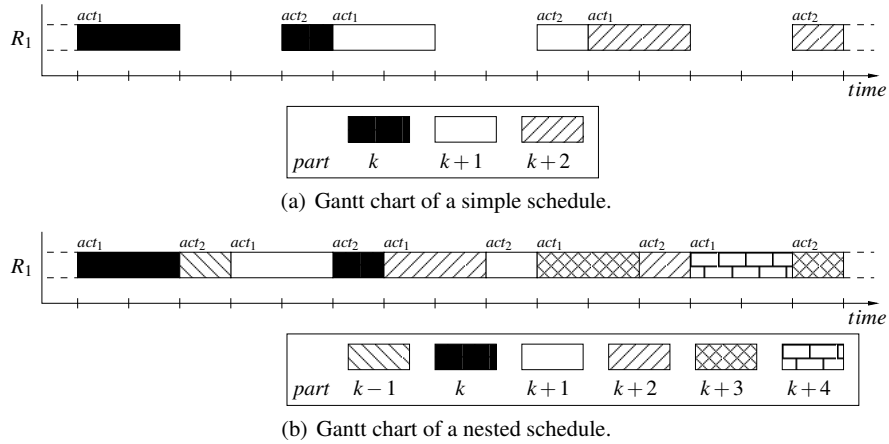

Fig. 1.14 Gantt chart of possible schedules of the manufacturing system.

of a future part (e.g., part $k + 1$) is executed in between activities of part k . In our example, however, this is only possible if the resting time between act_1 and act_2 is extended by 1 time unit (to be able to squeeze in the additional activities), which is of course possible as the two time units resting time represent a minimal time. The corresponding Gantt chart of this nested schedule is given in Fig. 14(b). From this, it can be seen that the total processing time of a single part is elongated from 5 to 6 time units, but the throughput of the system is increased to 1 part every 3 time units. To study this formally, the nested schedule is modeled as a TEG and represented as a linear system in the dioid $\mathcal{M}_m^{ax}[\gamma, \delta]$. To do this, one has to find the dependencies for the firing of transitions in the system. First of all, it is clear that the (minimal) timing information for the production of a single part remains unchanged, i.e.,

$$\begin{aligned}
 x_2 &\succeq \delta^2 x_1 && \text{processing time of } act_1 \\
 x_3 &\succeq \delta^2 x_2 && \text{resting time between } act_1 \text{ and } act_2 \\
 x_4 &\succeq \delta x_3 && \text{processing time of } act_2.
 \end{aligned}$$

Furthermore, as the capacity of the resource does not change, an activity for part k can still only start if the same activity for part $k - 1$ has been finished, i.e., one gets

$$\begin{aligned}
 x_1 &\succeq \gamma x_2 \\
 x_3 &\succeq \gamma x_4.
 \end{aligned}$$

Thus, to this point nothing has changed with respect to the dependencies of the simple schedule. What changes is the number of parts present in the system at the same time. Even though resource R_1 is still of single capacity, there are always two parts in the system (one being processed in act_1 or act_2 and the other one

resting). Thus, the dependencies of different activities executed on different parts to be processed change. Looking at the Gantt chart of the nested schedule, one can easily determine, that act_1 of part k has to be finished before act_2 of part $k-1$ can start. Similarly, act_1 of part $k+1$ cannot start until act_2 of part $k-1$ has been finished. Formally, this means

$$x_2 \preceq \gamma^1 x_3 \quad (1.51)$$

$$x_1 \succeq \gamma^2 x_4. \quad (1.52)$$

The first of these two inequalities warrants particular attention as it is the only constraint where the time of the occurrence of an event for a part is less or equal to the time of the occurrence of an event related to a previous part. With respect to timed event graphs, this means that at any time, the number of firings of transition x_2 should be at least one more than the number of firings of x_3 , i.e., there should always be a minimum of one token in the place between x_2 and x_3 , if the number of initial tokens is zero.

Remark 27 Note that the requirement $x_2 \preceq \gamma^1 x_3$ could of course also be written as $x_3 \succeq \gamma^{-1} x_2$. This, however, would lead to an acausal system model in $\mathcal{M}_{in}^{ax}[\gamma, \delta]$, as at least one entry in the system matrices would have a negative exponent in γ .

Clearly, the constraints (1.51) and (1.52) are very similar to the constraints of a time window. In fact, with respect to the event variable γ , the constraints on the minimal and maximal number of tokens can be handled analogously to the constraints on δ of time window constraints.

Example 25 (Nested schedules in manufacturing systems (cont.)) Reconsider the manufacturing system with a nested schedule from Ex. 24. Similar to time window constraints, it is possible to model this system in $\mathcal{M}_{in}^{ax}[\gamma, \delta]$ by

$$\mathbf{x} \succeq \underline{\mathbf{A}} \otimes \mathbf{x}$$

$$\mathbf{x} \preceq \overline{\mathbf{A}} \odot \mathbf{x}$$

where the matrices $\underline{\mathbf{A}}$ and $\overline{\mathbf{A}}$ are

$$\underline{\mathbf{A}} = \begin{bmatrix} \varepsilon & \gamma & \varepsilon & \gamma^2 \\ \delta^2 & \varepsilon & \varepsilon & \varepsilon \\ \varepsilon & \delta^2 & \varepsilon & \gamma \\ \varepsilon & \varepsilon & \delta & \varepsilon \end{bmatrix}, \quad \overline{\mathbf{A}} = \begin{bmatrix} \top & \top & \top & \top \\ \top & \top & \gamma & \top \\ \top & \top & \top & \top \\ \top & \top & \top & \top \end{bmatrix}.$$

As

$$\overline{\mathbf{A}}_* = \begin{bmatrix} e & \top & \top & \top \\ \top & e & \gamma & \top \\ \top & \top & e & \top \\ \top & \top & \top & e \end{bmatrix}$$

contains only monomials, i.e., elements that are either ε , \top or have a multiplicative inverse, the resulting matrix $\overline{\mathbf{A}}^*$ capturing all constraints is

$$\begin{aligned} \overline{\mathbf{A}}^* &= (\overline{\mathbf{A}} \cdot \mathbf{A}^*)^* \\ &= \begin{bmatrix} (\gamma\delta^3)^* & \gamma\delta(\gamma\delta^3)^* & \gamma^2\delta(\gamma\delta^3)^* & \gamma^2(\gamma\delta^3)^* \\ \delta^2(\gamma\delta^3)^* & (\gamma\delta^3)^* & \gamma^2\delta^3(\gamma\delta^3)^* & \gamma^2\delta^2(\gamma\delta^3)^* \\ \gamma^{-1}\delta^2(\gamma\delta^3)^* & \gamma^{-1}(\gamma\delta^3)^* & (\gamma\delta^3)^* & \gamma\delta^2(\gamma\delta^3)^* \\ \gamma^{-1}\delta^3(\gamma\delta^3)^* & \gamma^{-1}\delta(\gamma\delta^3)^* & \delta(\gamma\delta^3)^* & (\gamma\delta^3)^* \end{bmatrix}. \end{aligned}$$

Then, the complete system representation (with input and output elements) results in

$$\begin{aligned} \mathbf{x} &= \overline{\mathbf{A}}^* \mathbf{x} \oplus \mathbf{B}u = \left(\overline{\mathbf{A}}^*\right)^* \mathbf{B}u = \overline{\mathbf{A}}^* \mathbf{B}u \\ &= \begin{bmatrix} (\gamma\delta^3)^* \\ \delta^2(\gamma\delta^3)^* \\ \gamma^{-1}\delta^2(\gamma\delta^3)^* \\ \gamma^{-1}\delta^3(\gamma\delta^3)^* \end{bmatrix} u \\ \mathbf{y} &= \mathbf{C}\mathbf{x} = \overline{\mathbf{C}}\mathbf{A}^* \mathbf{B}u \\ &= \gamma^{-1}\delta^3(\gamma\delta^3)^* u. \end{aligned}$$

Obviously, the obtained transfer relation is not causal. Applying the causal projection Pr_{caus} results in

$$\mathbf{y} = \delta^6(\gamma\delta^3)^* u,$$

which is equivalent to the system behavior given in the Gantt chart of the nested schedule (Fig. 14(b)) of Ex. 24.

Obviously, by considering constraints on the minimal number of tokens in places, it is possible to model nested schedules of manufacturing systems. Such nested schedules may have a higher throughput and, therefore, may be more efficient than simple schedules which can be modeled without additional constraints in standard dioids.

1.5.4 Checking constraint feasibility

One remaining question is, what happens when the user makes a mistake and models an unfeasible constraint, e.g., when the upper bound of a time window constraint is smaller than the lower bound. Formally, this would mean that there are two constraints

$$x_j \succeq \delta^l x_i$$

$$x_j \preceq \delta^{\bar{l}} x_i$$

with $l > \bar{l}$. The corresponding TEG is given in Fig. 1.15. The resulting system model

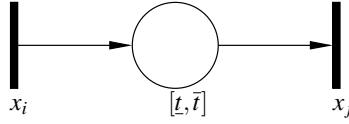

Fig. 1.15 Simple TEG with unfeasible time window constraints, i.e., $l > \bar{l}$.

of this small TEG with unfeasible time window constraints is

$$\begin{aligned} \overline{\mathbf{A}}^* &= (\overline{\mathbf{A}}_* \blacktriangleright \underline{\mathbf{A}}^*)^* \\ &= \left(\begin{bmatrix} e & \top \\ \delta^{\bar{l}} & e \end{bmatrix} \blacktriangleright \begin{bmatrix} e & \varepsilon \\ \delta^l & e \end{bmatrix} \right)^* \end{aligned}$$

with $\mathbf{x} = [x_i \ x_j]^T$. According to Lem. 4 the elements of matrix $\overline{\mathbf{A}} = (\overline{\mathbf{A}}_* \blacktriangleright \underline{\mathbf{A}}^*)$ can be computed by

$$[\overline{\mathbf{A}}]_{ij} = \bigoplus_{k=1}^n \left([\overline{\mathbf{A}}_*]_{ki}^{-1} \otimes [\underline{\mathbf{A}}^*]_{kj} \right).$$

Thus,

$$\begin{aligned} [\overline{\mathbf{A}}]_{11} &= e \otimes e \oplus \delta^{-\bar{l}} \otimes \delta^l \\ &= \delta^{(l-\bar{l})} \end{aligned}$$

$$\begin{aligned} [\overline{\mathbf{A}}]_{12} &= e \otimes \varepsilon \oplus \delta^{-\bar{l}} \otimes e \\ &= \delta^{-\bar{l}} \end{aligned}$$

$$\begin{aligned} [\overline{\mathbf{A}}]_{21} &= \varepsilon \otimes e \oplus e \otimes \delta^l \\ &= \delta^l \end{aligned}$$

$$\begin{aligned} [\overline{\mathbf{A}}]_{22} &= \varepsilon \otimes \varepsilon \oplus e \otimes e \\ &= e. \end{aligned}$$

Finally, the Kleene star of matrix $\overline{\mathbf{A}}$ has to be determined, e.g., by the algorithm given in Rem. 10. One central element in this algorithm is the term $(a_{21}a_{11}^*a_{12} \oplus a_{22})^*$, which for matrix

$$\overline{\mathbf{A}} = \begin{bmatrix} \delta^{(l-\bar{l})} & \delta^{-\bar{l}} \\ \delta^l & e \end{bmatrix} = \begin{bmatrix} a_{11} & a_{12} \\ a_{21} & a_{22} \end{bmatrix}$$

can be computed as

$$(a_{21}a_{11}^*a_{12} \oplus a_{22})^* = \left(\delta^{\underline{t}}(\delta^{(\underline{t}-\bar{t})})^* \delta^{-\underline{t}} \oplus e \right)^*.$$

Since $\underline{t} - \bar{t} > 0$ the term $(\delta^{(\underline{t}-\bar{t})})^* = \delta^\infty$. Consequently, one obtains

$$\begin{aligned} (a_{21}a_{11}^*a_{12} \oplus a_{22})^* &= (\delta^{\underline{t}}\delta^\infty\delta^{\underline{t}} \oplus e)^* \\ &= (\delta^{(\underline{t}+\infty-\bar{t})} \oplus e)^* \\ &= (\delta^\infty \oplus e)^* \\ &= (\delta^\infty)^* \\ &= \delta^\infty \end{aligned}$$

Using this result to compute the elements of matrix $\overline{\mathbf{A}}^*$ one obtains

$$\overline{\mathbf{A}}^* = \begin{bmatrix} \delta^\infty & \delta^\infty \\ \delta^\infty & \delta^\infty \end{bmatrix}$$

This result means, the only way to guarantee that the time window constraints are not violated is to never start the system, i.e., all events fire the first time at the earliest at time $t = \infty$.

Hence, if the user makes a mistake and asks for unfeasible constraints, the resulting linear model in $\mathcal{M}_{in}^{ax}[\gamma, \delta]$ will “tell” the user to check his or her constraints once more.

Remark 28 (Unfeasible constraints with respect to the number of tokens) *A similar effect can be observed if the user asks for unfeasible constraints with respect to the number of tokens. If the user models, for example,*

$$\begin{aligned} x_i &\succeq \gamma^{\underline{k}} \delta^\tau x_j \\ x_i &\preceq \gamma^{\bar{k}} x_j, \end{aligned}$$

i.e., at any time t transition x_i may fire at most \underline{k} times more often than x_j has fired at time $t - \tau$ and x_i shall fire at least \bar{k} times more often than x_j at time t . The corresponding system matrix $\overline{\mathbf{A}} = \overline{\mathbf{A}}_ \blacktriangleright \mathbf{A}^*$ is*

$$\overline{\mathbf{A}} = \begin{bmatrix} e & \gamma^{\underline{k}} \delta^\tau \\ \gamma^{-\bar{k}} & \gamma^{(\underline{k}-\bar{k})} \delta^\tau \end{bmatrix},$$

and with $\underline{k} - \bar{k} < 0$ and $\tau > 0$ and applying the Kleene star, one obtains

$$\overline{\mathbf{A}}^* = \begin{bmatrix} \gamma^{-\infty} \delta^\infty & \gamma^{-\infty} \delta^\infty \\ \gamma^{-\infty} \delta^\infty & \gamma^{-\infty} \delta^\infty \end{bmatrix} = \begin{bmatrix} \top & \top \\ \top & \top \end{bmatrix}$$

which again means that the constraints can only be met, if the system never starts at all.

Remark 29 *Of course, a TEG may have time window constraints as well as constraints on the number of tokens. However, it is not possible to have a time window constraint as well as a constraint on the minimal and maximal number of tokens for the simple TEG shown in Fig. 1.15. Consider, for example, the time window constraints*

$$x_j \succeq \delta^{\underline{t}} x_i \quad (1.53)$$

$$x_j \preceq \delta^{\bar{t}} x_i, \quad (1.54)$$

with $\underline{t} \leq \bar{t}$ and the constraints on the number of firings, e.g.,

$$x_i \succeq \gamma^{\underline{k}} \delta^{\tau} x_j \quad (1.55)$$

$$x_i \preceq \gamma^{\bar{k}} x_j, \quad (1.56)$$

with $\underline{k} \geq \bar{k}$ and $\tau > 0$. Clearly, the constraints (1.53) and (1.54) by themselves as well as the constraints (1.55) and (1.56) by themselves are feasible, combining these constraints, however, results in matrix

$$\begin{aligned} \bar{\mathbf{A}} &= \bar{\mathbf{A}}_* \blacklozenge \mathbf{A}^* \\ &= \begin{bmatrix} \top & \top \\ \top & \top \end{bmatrix}. \end{aligned}$$

Consequently, our approach cannot be applied as the resulting matrix $\bar{\mathbf{A}}$ indicates that the constraints can only be met if the system is prevented to fire at all.

1.6 Conclusions

In this chapter we have shown that timed event graphs are a suitable tool for the modeling of manufacturing systems characterized by synchronization and delay phenomena but devoid of choices. Furthermore, timed event graphs have a linear representation in an algebraic structure called idempotent semirings. We have introduced several such idempotent semirings, e.g., max-plus algebra, min-plus algebra, and $\mathcal{M}_{in}^{ax}[\gamma, \delta]$, and demonstrated with several examples their usefulness. As many manufacturing systems and their operation are subject to additional constraints, the standard notion of linear systems in dioids has been extended. Using our approach it is possible to model minimal and maximal operation times, i.e., time window constraints, as well as minimal and maximal numbers of work in progress, e.g., in systems operating with a nested schedule. Last but not least, we have shown, that the approach is relatively robust to mistakes in the modeling procedure. More precisely,

if unfeasible constraints are requested, the resulting system will indicate that some transitions are blocked from the beginning.

The obtained linear representation of the manufacturing system may be used to synthesize various forms of (feedback) control in the dioid framework. For a broad overview on this issue the interested reader is referred to [15] (see also Remark 26).

References

1. A. M. Atto, C. Martinez, and S. Amari. Control of discrete event systems with respect to strict duration: Supervision of an industrial manufacturing plant. *Computers & Industrial Engineering*, 61(4):1149–1159, 2011.
2. F. Baccelli, G. Cohen, G. J. Olsder, and J.-P. Quadrat. *Synchronization and Linearity – An Algebra for Discrete Event Systems*. Wiley, web edition, 2001.
3. T. S. Blyth. *Lattices and ordered algebraic structures*. Springer Verlag, 2005.
4. T. S. Blyth and M. F. Janowitz. *Residuation Theory*. Pergamon press, 1972.
5. T. Brunsch, L. Hardouin, C. A. Maia, and J. Raisch. Duality and interval analysis over idempotent semirings. *Linear Algebra and its Applications*, 437(10):2436–2454, November 2012.
6. G. Cohen. Residuation and applications. In *Algèbres Max-Plus et applications en informatique et automatique : Ecole d’informatique théorique*, Noirmoutier, 1998. INRIA.
7. G. Cohen, S. Gaubert, R. Nikoukhah, and J.-P. Quadrat. Second order theory of min-linear systems and its application to discrete event systems. In *Proceedings of the 30th CDC*, 1991.
8. B. Cottenceau. *Contribution à la commande des systèmes à événements discrets : synthèse de correcteurs pour les graphes d’événements temporisés dans les dioïdes*. PhD thesis, LISA - Université d’Angers, 1999.
9. B. Cottenceau, L. Hardouin, J.-L. Boimond, and J.-L. Ferrier. Synthesis of greatest linear feedback for timed event graphs in dioid. *IEEE Transactions on Automatic Control*, 44(6):1258–1262, 1999.
10. B. Cottenceau, L. Hardouin, J.-L. Boimond, and J.-L. Ferrier. Model reference control for timed event graphs in dioids. *Automatica*, 37(9):1451–1458, September 2001.
11. B. Cottenceau, L. Hardouin, M. Lhommeau, and J.-L. Boimond. Data processing tool for calculation in dioid. In *Proc. 5th International Workshop on Discrete Event Systems*, Ghent, Belgium, 2000.
12. B. Cottenceau, M. Lhommeau, L. Hardouin, and J.-L. Boimond. On timed event graph stabilization by output feedback in dioid. *Kybernetika*, 39(2):165–176, 2003.
13. S. Gaubert. *Théorie des systèmes linéaires dans les dioïdes*. PhD thesis, INRIA - Ecole des Mines de Paris, 1992.
14. D. Harding, M. Banks, S. Fogarty, and A. Binnie. Development of an automated high-throughput screening systems: a case history. *Drug Discovery Today*, 2(9):385–390, September 1997.
15. L. Hardouin, O. Boutin, B. Cottenceau, T. Brunsch, and J. Raisch. Discrete-event systems in a dioid framework: Control theory. In Carla Seatzu, Manuel Silva, and Jan H. van Schuppen, editors, *Control of Discrete-Event Systems*, volume 433 of *Lecture Notes in Control and Information Sciences*, chapter 22, pages 451–469. Springer Berlin / Heidelberg, 2013.
16. L. Hardouin, E. Menguy, J.-L. Boimond, and J.-L. Ferrier. Discrete event systems control in dioids algebra. *Journal Européen des Systèmes Automatisés*, 31(3):433–452, 1997.
17. R. Kumar and V. Garg. *Modelling and control of logical discrete event systems*. Kluwer Academic Publishers, 1995.
18. T.-E. Lee and S.-H. Park. An extended event graph with negative places and tokens for time window constraints. *IEEE Transactions on Automation Science and Engineering*, 2(4):319–332, October 2005.
19. M. Lhommeau, L. Hardouin, and B. Cottenceau. Disturbance decoupling of timed event graphs by output feedback controller. In *Workshop on Discrete Event Systems (WODES’2002)*, Zaragoza, Spain, October 2002.
20. C. A. Maia, C. R. Andrade, and L. Hardouin. On the control of max-plus linear system subject to state restriction. *Automatica*, 47(5):988–992, 2011.
21. C.-A. Maia, L. Hardouin, R. Santos-Mendes, and B. Cottenceau. Optimal closed-loop control of timed event graphs in dioids. *IEEE Transactions on Automatic Control*, 49(12):2284–2287, December 2003.
22. E. Menguy, J.-L. Boimond, L. Hardouin, and J.-L. Ferrier. Just in time control of timed event graphs: update of reference input, presence of uncontrollable input. *IEEE Transactions on Automatic Control*, 45(11):2155–2159, 2000.

23. I. Ouerghi. *Etude de systèmes (max,+)-linéaires soumis à des contraintes, application à la commande des graphes d'événements P-temporal*. PhD thesis, LISA - Université d'Angers, 2006.
24. I. Ouerghi and L. Hardouin. Control synthesis for p-temporal event graphs. In *Workshop on Discrete Event Systems (WODES'06)*, Ann Arbor, MI, USA, July 2006.
25. I. Ouerghi and L. Hardouin. A precompensator synthesis for p-temporal event graphs. In *Positive Systems : Theory and Applications (POSTA'2006)*, Grenoble, France, 2006.
26. J.-M. Proth and X.-L. Xie. *Petri nets: A tool for design and management of manufacturing systems*. John Wiley & Sons, 1996.
27. M. V. Rogers. High-throughput screening. *Drug Discovery Today*, 2(11):503–504, November 1997.
28. B. De Schutter and T. J. J. van den Boom. Model predictive control for max-plus linear discrete event systems. *Automatica*, 37(7):1049–1056, 2001.
29. G. Szász. *Introduction to lattice theory*. Academic Press New York and London, 1963.